



EFFECTS OF TERMS OF TRADE SHOCKS ON THE RUSSIAN ECONOMY

No. 48 / October 2019

WORKING PAPER SERIES

Natalia Turdyeva

Cover photo: Shutterstock.com

Address: 12 Neglinnaya street, Moscow, 107016
Tel.: +7 495 771-91-00, +7 495 621-64-65 (fax)
Website: www.cbr.ru

© Bank of Russia, 2019

All rights reserved. The views expressed in this Paper (these papers) are solely those of the authors and do not necessarily reflect the official position of the Bank of Russia. The Bank of Russia assumes no responsibility for the contents of the Paper (papers). Any reproduction of these materials is permitted only with the express consent of the authors.

Effects of terms of trade shocks on the Russian economy

Natalia Turdyeva

Bank of Russia

October 7, 2019

Abstract

The principal interest of the paper is the quantification of terms of trade shock response of the Russian economy on a detailed computable general equilibrium (CGE) model calibrated with Russian input-output data.

The results suggest a decrease of welfare of the representative consumer and real GDP with the deterioration of the terms of trade. In the Central scenario (a 10% decrease in the world price of crude oil, a 3% decrease in the world price of natural gas and an 8% decrease in the world price of petroleum products) welfare of the representative consumer decreases by -1,17% of benchmark consumption level or -0,58% of the base year GDP in the comparative static model. Percentage change of the GDP in the Central scenario of the comparative static model is of the same magnitude as representative agent's decrease in welfare in terms of the benchmark GDP: -1,55%.

Welfare changes associated with the Central scenario of the steady-state model, where capital stock adjusts to its long-term level, indicate a significant decrease in the welfare of the representative agent up to -2,64% of benchmark consumption level or -1,23% of the base year GDP. Percentage change of the GDP in the Central scenario of the steady-state model exceeds representative agent's decrease in welfare in terms of the benchmark GDP: -2,51%.

The model was validated by historical simulation with observed levels of exogenous parameters, mimicking change in economic environment from 2011 to 2015. The results of the historical simulation stress the importance of fiscal parameters (i.e. export taxes) in analysis of production behaviour of Russian extraction industries.

Key words: terms of trade, oil price shock, computable general equilibrium models, input-output table, industry output; CGE model validation.

JEL classification: F17, C68, D58.

Contents

1. INTRODUCTION	6
2. LITERATURE REVIEW	7
THE EFFECT OF THE SHOCK OF THE TERMS OF TRADE ON THE OUTPUT OF INDUSTRIES.....	7
TOTAL OUTPUT AND REAL EXCHANGE RATE	9
ESTIMATING EFFECTS OF A ToT SHOCK WITH A GENERAL EQUILIBRIUM MODEL.....	11
MODELS OF COMPUTABLE GENERAL EQUILIBRIUM FOR THE RUSSIAN ECONOMY	12
3. MODEL DESCRIPTION	12
3.1. THE COMPARATIVE STATIC MODEL	13
<i>ECONOMIC AGENTS.....</i>	<i>13</i>
<i>INDUSTRIES.....</i>	<i>15</i>
3.2. STEADY-STATE MODEL	16
4. BENCHMARK DATASET	17
4.1. SOCIAL ACCOUNTING MATRIX	17
4.2. ELASTICITIES.....	18
5. RESULTS: TERMS OF TRADE DECREASE	20
5.1. SCENARIO DEFINITION.....	20
5.2. SIMULATIONS RESULTS: COMPARATIVE STATIC MODEL	21
5.3. SIMULATIONS RESULTS: STEADY-STATE MODEL	22
5.4. CHANGES ON THE INDUSTRY LEVEL.....	24
OUTPUT CHANGES	24
PRICE CHANGES	25
5.5. VALIDATION OF THE MODEL: HISTORICAL SIMULATIONS	27
6. CONCLUSION.....	31
REFERENCES.....	32

APPENDIX I. ANALYTICAL STRUCTURE OF THE MODEL	37
EQUATIONS	37
<i>HOUSEHOLD'S PROBLEM</i>.....	37
<i>GOVERNMENT BUDGET</i>.....	38
<i>SUPPLY FOR DOMESTIC AND EXPORT MARKETS</i>.....	38
<i>BALANCE OF PAYMENTS</i>.....	39
ARBITRAGE CONDITIONS	39
MARKET EQUILIBRIUM CONDITIONS.....	41
SYMBOL MAP.....	42
APPENDIX II DATA AND PARAMETRIZATION.....	45
INDUSTRY LIST.....	45
APPENDIX III SIMULATIONS DESIGN.....	47
APPENDIX IV SIMULATION RESULTS.....	48

1. Introduction

The focus of this paper is on the output response on detailed industry level. The aim is to study propagation of oil price shock in the simplest general equilibrium settings possible, in a small open nested-CES economy with a representative agent, perfectly competitive cost-minimizing producers and inelastic factor supplies. This paper examines the impact of changes in world prices on the Russian economy. In particular, I am interested in the change in production as a result of changes in world prices for the main Russian export and import commodities. The model presented in the paper belongs to the class of computable general equilibrium (CGE) models, it has a detailed industry structure, which allows tracing the effect of changes in world prices on all aspects of the Russian economy.

This article examines the impact of changes in world prices on the Russian economy. In particular, I am interested in the change in production as a result of changes in world prices for the main Russian export and import commodities.

A number of recent macro studies ((Atalay 2017), (Acemoglu, Ozdaglar, and Tahbaz-salehi 2017) (Burstein, Kurz, and Tesar 2008)) stressed importance of explicit introduction of the intermediates in the models assessing effects of external shocks, which is a well-established practice in the computable general equilibrium methodology. Models of this class permit introduction of rich details and complex production structures as well as optimizing behaviour of economic agents.

The model presented in the paper belongs to the class of computable general equilibrium (CGE) models, it has a detailed industry structure, which allows tracing the effect of changes in world prices on all aspects of the Russian economy.

The results suggest a decrease of welfare of the representative consumer and real GDP with the deterioration of the terms of trade. In the Central scenario (a 10% decrease in the world price of crude oil, a 3% decrease in the world price of natural gas and an 8% decrease in the world price of petroleum products) welfare of the representative consumer decreases by -1,17% of benchmark consumption level or -0,58% of the base year GDP in the comparative static model. Percentage change of the GDP in the Central scenario of the comparative static model is of the same magnitude as representative agent's decrease in welfare in terms of the benchmark GDP: -1,55%.

Welfare changes associated with the Central scenario of the steady-state model indicate a significant decrease in the welfare of the representative agent up to -2,64% of benchmark consumption level or -1,23% of the base year GDP. Percentage change of

the GDP in the Central scenario of the steady-state model exceeds representative agent's decrease in welfare in terms of the benchmark GDP: -2,51%. The GDP response in the steady-state model is in line with estimates obtained in compatible work (Полбин 2017).

These results exceed welfare changes in the Central scenario of the static model, and we can refer to these values as upper bound of possible changes in welfare in the dynamic modelling exercise (Rutherford and Tarr 2003).

2. Literature review

The effect of the shock of the terms of trade on the output of industries

The dependence of the Russian economy on oil prices manifests itself in 2014-2015 (see Figure 1), when, following the reduction in oil prices and the restriction of access to capital markets, Russia's economy entered a recession (World Bank Group 2015).

Figure 1. Real GDP of the Russian Federation, in % to the previous year

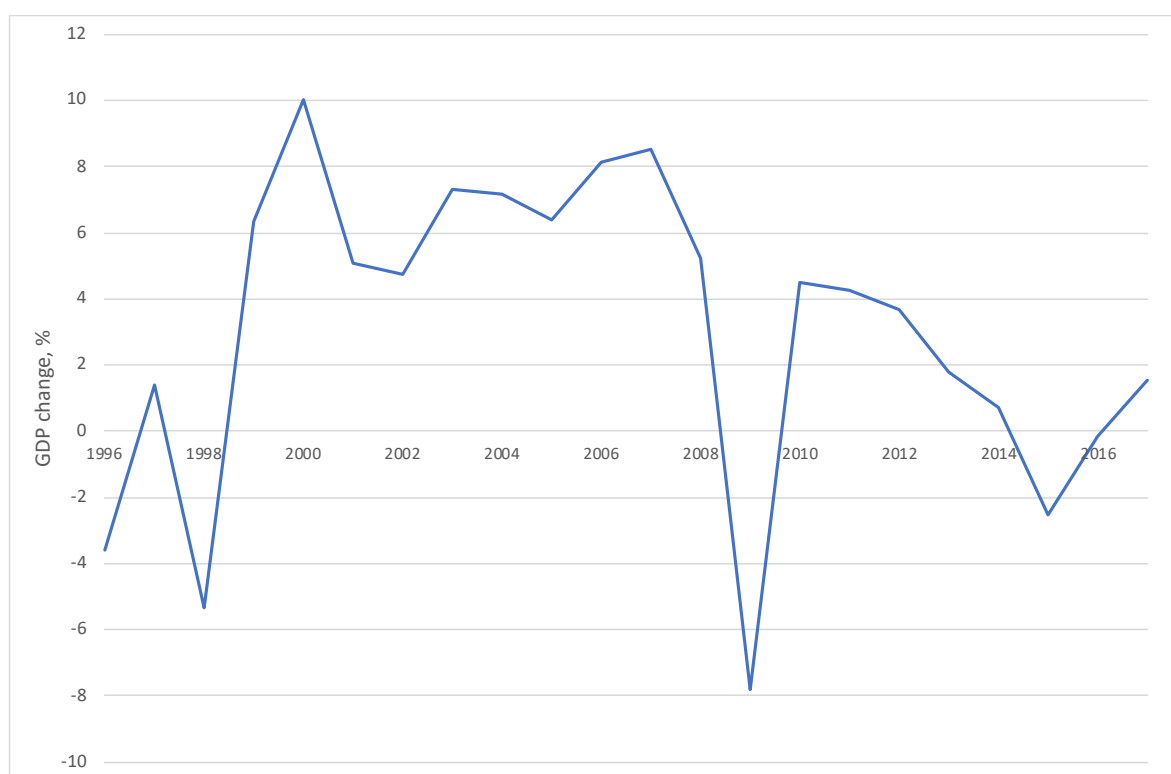

Source: Rosstat.

The main reasons for the decline in production in 2015 were a sharp drop in oil prices, a subsequent depreciation of the rouble with a corresponding increase in inflation.

The situation was complicated by the loss of investor confidence resulting from economic, political and external economic circumstances.

The decline in prices for oil and oil products, which are the key Russian exports, while maintaining world prices for goods imported into Russia, led to a reduction in the ratio of prices of export goods to the prices of imported goods, or terms of trade (Reinsdorf 2010).

Numerous studies (International Monetary Fund 2017), (Cavalcanti, Mohaddes, and Raissi 2015) find that GDP growth (see Figure 2) and other macroeconomic characteristics of commodity-exporting countries, including Russia, depend to a greater extent on changing terms of trade than comparable countries, which are not commodity exporters.

Figure 2. Contribution of terms of trade to GDP per capita change, commodity-exporting countries and EMDE, in average for developing countries.

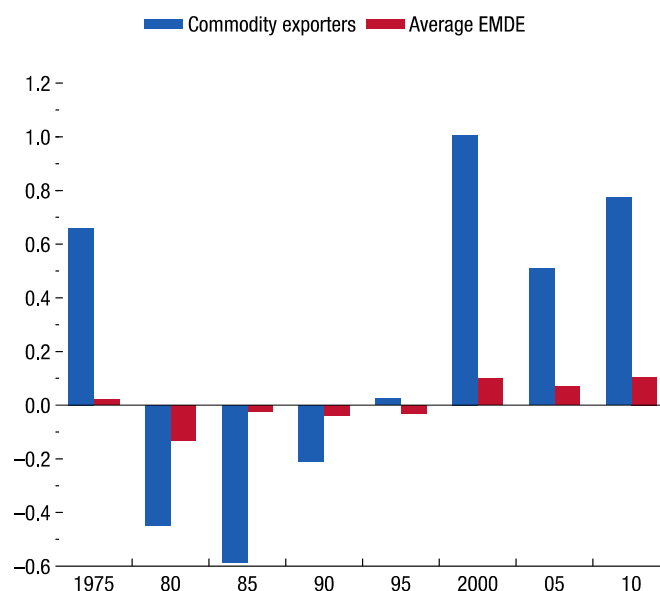

Source: International Monetary Fund, (International Monetary Fund 2017), p. 74.

There are various estimates of the extent to which the shocks of the terms of trade cause business cycles in developing countries. For a long time economists considered that up to 30% of the change in output and other macroeconomic indicators was due to changes in terms of trade (Mendoza 1995) and (Kose 2002). The latest estimates (Schmitt-Grohé and Uribe 2018) significantly reduce this estimate, referring to less than 10% of the relationship between changes in terms of trade and the movement of gross output. Despite the uncertainty about the impact of the terms of trade on the economy of developing countries on average, the mechanisms of influence are well described. Idrisov et al. (Идрисов, Пономарев, and Синельников-Мурылёв 2015) note two main channels

of the impact of terms of trade on the Russian economy: a reduction in disposable income and a devaluation of the rouble.

The impact of the real rouble exchange rate on the macroeconomic parameters of the economy and aggregate output has always been in the focus of attention of economists. Let us consider below a few works devoted to this topic in general and in application to the Russian economy.

Total output and real exchange rate

There is no consensus in the theoretical literature on the impact of a change in the exchange rate of the national currency on the real output. Gylfason and Schmid (Gylfason and Schmid 1983) discuss a possible channel for the negative impact of the weakening of the national currency on aggregate output: in the case of a large share of imports in intermediate consumption, devaluation leads to an increase in the costs of domestic production, which can cause a fall in supply, as a consequence, a reduction in the equilibrium output. This channel of influence is the more important, the less the elasticity of substitution of imported intermediates by domestic in the production processes of domestic firms.

For the economy as a whole, the substitution of imported goods by domestic largely depends on the structure of the preferences of households: if imports and domestically produced goods are easily substituted in the consumption, then with the increase in import prices there will be a switch to consumption of domestic goods, and, as shown in the work of Kadochnikov et al. (Кадочников, Синельников-Мурылёв, and Четвериков 2003), this will lead to an increase in the domestic output. If domestic and imported goods are compliments and do not replace each other in consumption, the increase in import prices will be accompanied by a decrease in demand for home products, which is due to the predominance of the income effect over the substitution effect, and as a result, the demand for home products will decrease.

An important channel of propagation of exchange rate swings on the aggregate output may be the relationship of exchange rate and investment demand. As noted in a number of growth models with technology adaptation (Easterly et al. 1994), the weakening of the national currency leads to a rise in the cost of borrowing technology. This leads to a drop in investment, and, ultimately, to a decrease in the aggregate output. As Badasen and co-authors (Бадасен, Картаев, and Хазанов 2015) note, this channel of influence is especially important for developing economies in which technology import plays an important role.

In the works of Aghion and co-authors (Aghion, Bacchetta, and Banerjee 2000), Greenwald and Stiglitz (Greenwald and Stiglitz 1993), Gatti et al. (Gatti et al. 2007), it is shown that in the case of a large volume of borrowings of the private sector in foreign currency, after a devaluation, debt servicing becomes more complicated due to its growth in the national currency. This can lead to a reduction in the cumulative output.

The general direction of the change in the aggregate and industry output caused by the exchange rate changes depends on the conditions prevailing at a particular moment in the given economy, and economic theory does not give a single answer to the question of the direction of change. In part, this thesis is confirmed by the heterogeneous results obtained for the Russian economy in the studies of various authors over the past few years.

Dynnikova (Дынникова 2000), on the basis of the theoretical model, came to the conclusion that in the period from 1993 to 1997, the strengthening of the real exchange rate of the rouble was accompanied by an increase in output, presumably due to lower prices for imported components and intermediate goods.

Kontorovich's empirical findings (Конторович 2001) show that strengthening the real rouble/dollar exchange rate by 1% with a lag of several months is accompanied by a reduction in the intensity index of industrial production by approximately 0.2%.

In the work of Kadochnikov et al. (Кадочников, Синельников-Мурылёв, and Четвериков 2003), a link was made between the strengthening of the national currency and the growth in demand for imports: the strengthening of the real exchange rate by 1% leads to the replacement of domestic goods with imports by 0.77% on average in the economy.

Kartayev (Картаев 2009) concluded that the weakening of the national currency by 1% leads to an increase in real GDP of Russia by 0.66%. From the point of view of sector dynamics, it was concluded that the weakening of the rouble does not lead to changes in the production of the extractive industry, but at the same time, it leads to an increase in the output of the manufacturing industry.

Vdovichenko et al. (Вдовиченко, Дынникова, and Субботин 2003) also expressed the idea that the manufacturing industry reacts more strongly to fluctuations in exogenous factors, including the real exchange rate. From the point of view of the difference in the sectoral response to the change in the real exchange rate, the industries were divided into three groups: losers of the strengthening the real exchange rate (fuel, wood pulp and paper, chemical and petrochemical, non-ferrous metallurgy), insensitive

to real exchange rate changes (food and mechanical engineering) and winners (light industry, ferrous metallurgy, construction materials industry and electric power industry).

In the work of Badasen, Kartaev, and Khazanov (Бадасен, Картаев, and Хазанов 2015), based on econometric research, it was concluded that when the exchange rate of the rouble depreciates, the most favourable effect is on export-oriented industries, as well as on industries with a low share of imports in costs.

The studies referred above generally agree with the positive influence of the relative weakening of the domestic currency on domestic output. But it should be noted, that in a case of a ToT shock, usually both channels of influence are present: income effect and exchange rate. Thus, in order to simulate effect of a ToT deterioration of the detailed industry structure of the Russian economy there is a need of a structural model. One of possible solutions is use of the computable general equilibrium model.

Estimating effects of a ToT shock with a general equilibrium model

Computable (applied) general equilibrium model is a system of equations describing behaviour of economic agents in an economy. The numerical parameters of the model equations are based on statistical data of one year or averaged data over several years. The procedure for calculating the parameters of a model is called calibration. The model is calibrated so that the base year data is obtained as the initial equilibrium.

Scenario forecasts are set by changing one or several controls, for example, by changing exogenous world prices for export or import goods. After changing the controls, a new equilibrium is obtained. The new equilibrium reflects the effect of the proposed changes in the controls. Resulting changes in endogenous variables are obtained by comparing the basic data set and the new equilibrium obtained as a result of the experiment.

Models of computable general equilibrium (CGE models) have traditionally been the most effective and most widely used tool for assessing possible changes in foreign trade (Hertel 2013), taxation (Dixon and Rimmer 2016), public expenditure (Holmøy and Strøm 2013), social security (Fehr 2016), demography (Zodrow and Diamond 2013), immigration (Fehr et al. 2013), labour markets (Dixon, Koopman, and Rimmer 2013), environment (Böhringer et al. 2015), as well as assessing the effects of natural (Shibusawa et al. 2011) and man-made disasters (Rose and Liao 2005). CGE models are the only practical way to quantify these effects at the level of industries, regions (Giesecke and Madden 2013) and socio-economic groups (Horridge et al. 2013).

Even at the dawn of its existence, computable general equilibrium models were used to assess the effects of the shock of terms of trade on the welfare, changes in output and factor income (Devarajan and Robinson 2013). Subsequently, a variety of studies were conducted both at the level of one country (Dixon, Koopman, and Rimmer 2013), often in a regional breakdown (Dong et al. 2017), or in the framework of global models (Timilsina 2015).

Models of computable general equilibrium for the Russian economy

Examples of the use of computable general equilibrium models for Russia include: Makarov (Макаров 1999), Zemnitsky (Земницкий 2003), Bakhtizin (Бахтизин 2003), Alekseev, Turdyeva, Yudaeva (Alekseev, Turdyeva, and Yudaeva 2003), Alekseev, Sokolov, Turdyeva, Yudaeva (Alekseev et al. 2004), Jensen, Rutherford and Tarr (Rutherford and Tarr 2004), (D. G. Tarr and Rutherford 2004), (Helm and Rutherford 2004), Rutherford, Tarr, Shepotilo (D. G. Tarr, Shepotylo, and Kouduyarov 2005), Alekseyev et al. (Алексеев et al. 2004), Besstremyannaya, Bakhtizin (Besstremyannaya and Bakhtizin 2006), Volchkova and others . (Волчкова et al. 2006), Rutherford and Tarr (D. Tarr 2006), Kolik, Radziwill, Turdiyeva (Kolik, Radziwill, and Turdyeva 2015), Bohringer et al. (Böhringer et al. 2015).

The effects of the shock of the terms of trade and the subsequent recession of 2014-2015 on welfare distribution in Russia are considered in the work of Bussolo and Luongo (Bussolo and Luongo 2017). The authors concluded that a 50% reduction in oil prices would lead to a significant decline in oil production and refining (-13%), a reduction in construction industry production (-5%) and transport (-1.3%). The main gain will be for the export industries of manufacturing (+ 12.7%), agriculture (+ 9.5%), other manufacturing (+ 8.2%) and other extractive industries (+ 5.1%), and the food industry (+ 2.3%). Among other consequences, the authors note a fall in the well-being of the population by 6.88% in terms of consumption.

3. Model Description

I present two models: the core comparative static model with inelastic factor supply and a steady-state model with a variable capital stock. The steady-state model is an extension of the comparative static model, it solves for time-invariant capital stock, i.e. cost of investment equals the discounted stream of rents on installed capital. The goal of the steady-state model is to “evaluate the upper bound of welfare gains in a Solow type model” (Rutherford and Tarr 2003).

3.1. The comparative static model

The structure of the core model is close to the CRTS model used in Böhringer et al. (Böhringer et al. 2015). The model is based on optimizing behaviour of all economic agents, supply and demand balances in all markets for goods, services, and factors. Budgets are balanced for all agents.

The algebraic formulation presented in the appendix corresponds to the core model of a small open nested-CES economy with perfectly competitive cost-minimizing producers and inelastic factor supplies. Economic agents resented in the model are households, enterprises, investment sector, and government. Consumers of final and intermediate goods differentiate between domestic and imported goods, i.e. the Armington (Armington 1969) assumption is used (Figure 3).

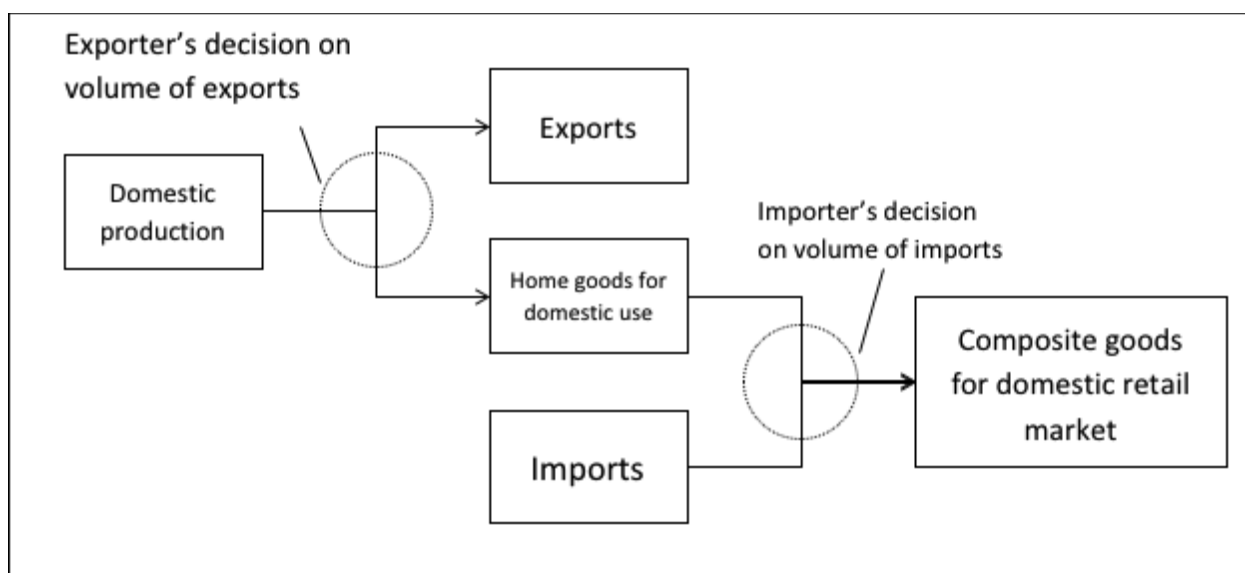

Figure 3. Structure of products differentiation in the model.

Source: the author

Economic agents

Economic agents of the model are: a representative household, enterprises, the government and a savings-investment bank (see Figure 4). The government collects direct and indirect taxes with fixed ad-valorem tax rates, saves an amount equal to trade surplus in the base year in foreign currency (\bar{V}), then saves a fixed portion of the tax revenue in the domestic savings-investment bank, and purchases goods (g_i) on the final market.

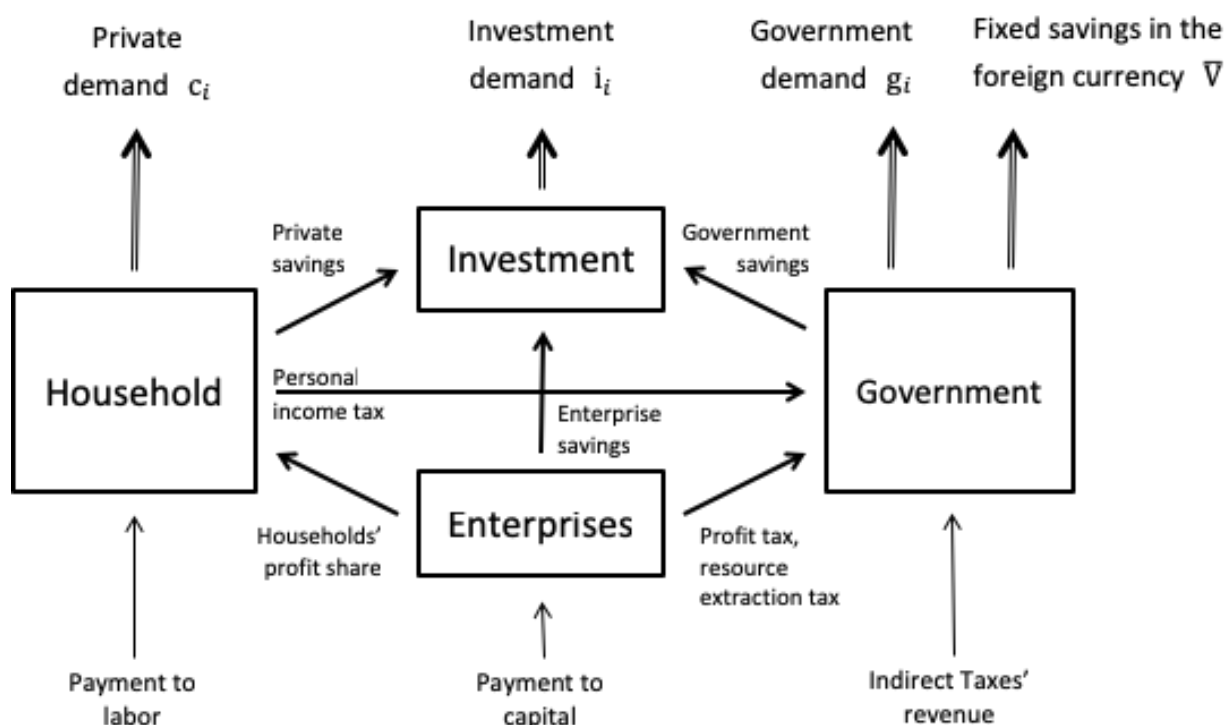

Figure 4. Structure of income and spending of economic agents in the model

Source: the author

I assume that labour belong to households and capital belong to enterprises. Enterprises receive all capital income, pay direct corporate taxes (the corporate profit tax and the resource extraction tax), save a fixed portion of an after-tax capital earnings and transfers the rest to shareholders. I assume that there is no foreign ownership of Russian companies, thus all payments to shareholders are transferred to the domestic households.

The representative domestic household receives labour remuneration and share of profit from the enterprises (discussed above). Households pay personal income tax, saves a portion of the after-tax income and uses the rest on private consumption (c_i).

The savings-investment bank receives private, enterprise, and government savings. Savings of all economic agents in the model are savings-driven (Lofgren, Thomas, and El-said 2002), in other words, each economic agent saves a fixed share of its budget. The savings-investment bank spends all available funds on purchase of goods on the final market (i_i).

There is no international ownership of factors, i.e. model does not account for non-zero net factor payments. Default external closure of the core model states that foreign savings of the government is fixed and exchange rate is fully flexible. Government's

foreign savings are fixed on the base year level \bar{V} , which equals to the current account surplus (or, in the case of $NFP=0$, to the trade surplus).

Industries

There are 52 industries (Table 6) producing goods and services, each described by a representative firm. Cost-minimizing firms operate in free-entry markets, which leads to zero profit, i.e. marginal returns for an individual firm equal marginal cost.

Production technologies are characterized by constant returns to scale. Output (Y) is a Leontief ($\sigma^Y = 0$)¹, combination of value added (VA) and intermediate goods (INT). Value added is a Cobb-Douglas ($\sigma^{VA} = 1$) aggregate of primary factors (mobile labour (L), mobile (K) and specific capital (SK)) and intermediate goods and services (INT) (see Figure 5).

Intermediate goods are a bundle of imported (m_{ij} – imports of commodity i for industry j) and domestically produced intermediates (d_{ij}). Bundling of domestic and imported intermediates is done for each industry and each type of good separately. All bundling techniques for the intermediate products are described by CES functions and share the same low (Atalay 2017) elasticity of substitution between domestic and imported goods ($\sigma^m = 0.4$), share parameters for each industry i and each good j are calibrated on detailed information provided by Russian input-output tables². Relatively low value of elasticity of substitution between domestic and imported intermediates reflects high level of complementarity of imports in firms' intermediate consumption (Березинская and Ведев 2015).

Domestically produced goods (Y) are split between domestic (D) and export markets (X) on the basis of relative prices at home and export markets. This transformation, i.e. a decision of an exporter, is described by the constant elasticity of transformation (CET) function. Default value of elasticity of transformation η equals 0.15. This relatively low level of the elasticity of transformation corresponds to values reported

¹ σ^Y – is the elasticity of substitution between value added (VA) and intermediate consumption (INT) in the upper-level production function. Notational convention: σ (sigma) - denotes elasticity of substitution in various production and bundling functions; η (eta)- elasticity of transformation between domestic goods for domestic market and exports. Please note, that limit case of a CES function with elasticity of substitution $\sigma = 0$ is the Leontief function, and $\sigma = 1$ is the Cobb-Douglas function.

² Base input-output tables for the Russian Federation were estimated for year 2011 (http://www.gks.ru/wps/wcm/connect/rosstat_main/rosstat/ru/statistics/accounts/#), more on data sources in the relevant chapter. Information on the composition of intermediate consumption is provided by use tables for domestic and imported goods.

in (Tokarick 2014) and (IMF 2017) and reflects problems in reallocation of resources from domestic supply to export markets that Russian economy faces.

Domestically produced goods for the domestic market (D), are bundled with imports (M). The composite good (A) is supplied to the domestic market where it serves final demand by the representative agent. The bundling of domestic and imported goods is described by constant elasticity of substitution (CES) function with elasticity ($\sigma^A = 4$). This value is close to the average of Armington substitution elasticities between domestic and imported goods in GTAP 9 database (Aguiar, Narayanan, and McDougall 2016).

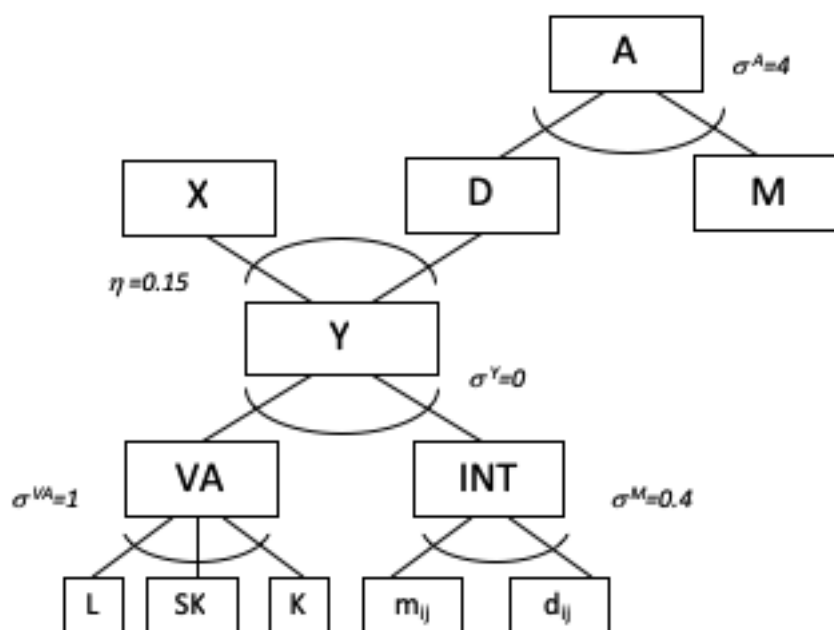

Figure 5. Structure of industrial production and supply of composite goods for the final market.

Source: Author

3.2. Steady-state model

The steady-state model is an extension of the core comparative static model. The goal of the steady-state calculation is to evaluate the upper bound (Rutherford and Tarr 2003) on welfare changes associated with terms of trade change for the Russian economy.

In the comparative static model the price of capital varies, while total supply of capital is fixed. In the steady-state model the mobile capital stock and investment demand are endogenously determined while the price of capital is constant. In other words, the steady-state model solves for time-invariant capital stock. In the steady-state model

optimal capital stock is such that cost of investment equals the discounted stream of rents on installed capital³. “This can be viewed as a multi-sector version of the “golden rule” equilibrium” (Rutherford and Tarr 2003).

4. Benchmark dataset

The dataset for the model consists of two sets: economic indicators, which describe economy of the Russian Federation for the base year (2011) in the form of the Social accounting matrix (SAM) (see part 4.1) and the second set of behavioural parameters derived from the relevant literature, which consists of different elasticities of substitution (see part 4.2).

4.1. Social accounting matrix

The social accounting matrix for the model describes a snapshot of the economic activities of Russia at year 2011, which is the base year in our case. The SAM is a square matrix, each account is represented by a row and a column (Pyatt 1991). Row entities correspond to income of the respective account, while column depicts payments of the account. Accounts of the SAM consist of production activities, goods, factors of production, economic agents, and economic policy instruments. For more information on the social accounting matrix format of representing the economic data see (Pyatt and Round 1985).

Main sources of the data for the SAM are Russian Input-Output (IO) tables for 2011⁴, as well as National accounts for 2011 (Росстат 2017). The Input-Output tables consist of a resource table, use tables in buyers' and basic prices, use tables of domestically produced and imported products, tables with transport and trade margins, and a table of taxes. Sectoral and commodity details of the original tables were aggregated to 52 commodity and industries (Table 6). Development of a dataset for a CGE model from an IO table in well-documented process (Rutherford and Paltsev 1999).

The IO tables do not contain information on direct taxes and other transfers between economic agents. This information was obtained from national accounts (see Table 1).

³ In the present version of the model depreciation is set to zero.

⁴ Rosstat, 2017, Russian Input-Output Tables for year 2011, retrieved from (http://www.gks.ru/free_doc/new_site/vvp/baz-tev-2011.xlsx) on September 05th, 2019

Table 1. Transfers between economic agent in the model

		government	households	enterprises	savings- investment	exports
		gov	hh	ent	s-i	row
government	gov					
households	hh			22,2187		
enterprises	ent					
savings-investment	s-i	1,0882	7,041	6,6067		
imports	row	5,4872				

Source: the author

An aggregated version of the SAM used in the model is presented in the appendix (Table 14).

4.2. Elasticities

In this section I stick to the following notational convention: σ (sigma) – denotes elasticity of substitution in various production and bundling functions; η (eta) – elasticity of transformation between domestic goods for domestic market and exports⁵.

Output in each industry is produced with a nested production function. The upper nest is a Leontief combination of value added (VA) and intermediate goods (INT), $\sigma^Y = 0$ – is the elasticity of substitution between value added (VA) and intermediate consumption (INT) in the upper-level production function. This type of nested production function was used in several models of the Russian economy, see (Böhringer et al. 2015).

Value added is a Cobb-Douglas aggregate of primary factors (mobile labour (L), mobile (K) and specific capital (SK)) and intermediate goods and services (INT) (see Figure 5). $\sigma^{VA} = 1$ is the elasticity of substitution between different factors in production of value added.

Domestic and imported intermediates are bundled in each industry and for each type of good separately. All bundling techniques for the intermediate products are described by CES functions and share the same low (Atalay 2017) elasticity of substitution between domestic and imported goods ($\sigma^m = 0.4$), share parameters for each industry i and each good j are calibrated on detailed information provided by Russian

⁵ Please note, that limit case of a CES function with elasticity of substitution $\sigma = 0$ is the Leontief function, and $\sigma = 1$ is the Cobb-Douglas function (K. J. Arrow et al. 1961).

input-output tables⁶. Relatively low value of elasticity of substitution between domestic and imported intermediates reflects high level of complementarity of imports in firms' intermediate consumption (Березинская and Ведев 2015).

Transformation of domestically produced goods (Y) between domestic (D) and export markets (X) is described by the constant elasticity of transformation (CET) function. Default value of elasticity of transformation η equals 0.15. This relatively low level of the elasticity of transformation corresponds to values reported in (Tokarick 2014) and (IMF 2017) and reflects problems in reallocation of resources from domestic supply to export markets that Russian economy faces.

The bundling of domestic and imported goods is described by constant elasticity of substitution (CES) function with elasticity ($\sigma^A = 4$). This value is close to the average of Armington substitution elasticities between domestic and imported goods in GTAP 9 database (Aguiar, Narayanan, and McDougall 2016).

Table 2. Central values of elasticities in the model

	Elasticity	Description	Value	Reference
1	η	elasticity of transformation between supply to domestic and export markets	0.15	(Tokarick 2014) (IMF 2017)
2	σ^m	elasticity of substitution between domestic and imported goods in intermediate consumption	0.4	(Atalay 2017)
3	σ^Y	elasticity of substitution between value added and intermediate goods in the production function	0	(Böhringer et al. 2015)
4	σ^{VA}	elasticity of substitution between different factors in production of value added	1	(Böhringer et al. 2015)
5	σ^A	elasticity of substitution between domestic and imported goods in the Armington aggregation function for production of final goods	4	(Aguiar, Narayanan, and McDougall 2016).

Source: respective papers

⁶ Rosstat, 2017, Russian Input-Output Tables for year 2011, retrieved from (http://www.gks.ru/free_doc/new_site/vvp/baz-tev-2011.xlsx) on September 05th, 2019. Information on the composition of intermediate consumption is provided by use tables for domestic and imported goods.

5. Results: Terms of trade decrease

One of my principal interests is the quantification of terms of trade shock response of the Russian economy on a detailed CGE model calibrated with Russian input-output data. A number of studies ((Atalay 2017), (Acemoglu, Ozdaglar, and Tahbaz-salehi 2017) (Burstein, Kurz, and Tesar 2008)) stressed importance of implicit introduction of the intermediates in the models assessing effects of external shocks. The assessment of effects of a terms of trade shock on the macro and industry level is completed with a help of a detailed computable general equilibrium model. Models of this class permit introduction of rich details and complexity of production structures as well as optimizing behaviour of economic agents.

5.1. Scenario definition

The central scenario is a 10% decrease in world prices of crude oil, accompanied by a 3% decrease in the world price of natural gas, and an 8% decrease in the world price of petrochemical products.

Relationship between the world oil and gas prices

There is a growing literature on long-term relationship between global crude oil and natural gas prices (Nick and Thoenes 2014). Recently, the long-run oil–gas price relationship has been challenged quite often, as these two prices have shown evidence of decoupling from each other (Ramberg et al. 2017). Based on (Zhang and Ji 2018), we adopt factor of 0.3, describing relationship between change in the world price of oil and change of the world price of natural gas. Thus, in our central scenario a 10% decrease in the world price of oil is accompanied with a 3% change in the world price of natural gas.

Relationship between the world oil and oil products' prices

Strong technological connections (Ramberg et al. 2017) between crude oil and oil products dictates relatively high factor of 0,8, describing relationship between crude oil and oil products world prices for Russian exports (Polanco Martínez, Abadie, and Fernández-Macho 2018). In our central scenario, a 10% decrease in the world price of crude oil is accompanied by an 8% decrease in the world price of oil products.

We can present Central scenario as a composition of three scenarios: “Oil”, “Natural gas” and “Petroleum products”. Each of these scenarios model decrease in the world prices of one separate good. Thus, the Central scenario is summarized as a simultaneous decrease in three world prices for Russian exports:

- Crude oil (scenario “Oil”: decrease of the world price for crude oil by 10%);
- Natural gas (scenario “Natural gas”: decrease of the world price for Natural gas by 3%);
- Petroleum products (scenario “Petroleum products”: decrease of the world price for Petroleum products by 8%).

5.2. Simulations results: comparative static model

Overall economic impacts: static model, Central scenario

Overall economic impact for the Central scenario in the settings of the static model are shown in the table below (Table 9). The results are presented for the Central scenario and its components. Welfare changes associated with the Central scenario indicate a significant decrease in the welfare of the representative agent up to -1,17% of benchmark consumption level or -0,58% of the base year GDP.

Percentage change of the GDP in the Central scenario is of the same magnitude as representative agent’s decrease in welfare in terms of the benchmark GDP (-1,54%).

Major driver of the decline in the GDP is government consumption (-4,28%), due to fall in oil taxes (export tariffs). Decline in the household’s consumption (-1,17%) reflects households’ income decline, caused by decline in remuneration of mobile factors of production (wage decreases by -1,33%, mobile capital rent – by -0,73%). The most significant decline in income is the decline of -3,22% rent of the specific capital in the oil industry. Investment decreases as well (by -0,87%). The only component of the final demand that experiences growth is real aggregated exports (1,23%), partly due to performance of the exchange rate (+4,24%).

The external closure of the model fixes trade balance in real terms and lets the exchange rate to adjust to changes in relative prices of exported and imported goods. The exchange rate is defined in units of local currency to units of foreign currency, thus an increase in the value of the exchange rate means depreciation of the local (domestic) currency. A decrease in the exchange rate means that domestic currency strengthens.

The Central scenario is associated with a 4,24% increase in the exchange rate. This means that all imported goods are 4,24% more expensive than in the base year.

Numeraire of the static model is consumer price index, thus CPI change in all scenarios equal to zero. Since only relative prices matters in the computable general equilibrium models, all other prices are quoted in terms of the numeraire (CPI in our case). Given that CPI is fixed, changes in the exchange rate reflect changes in the real exchange

rate. In the central scenario wages change by -1,33% and return to mobile capital by -0,73%.

Return to specific capital in extracting industries or natural rent, decreases for crude oil production (-3,22%), indicating reduction of production activities.

All other extracting sectors feel much better with increase in return to specific capital in the Central scenario. The resource rent in production of natural gas rises (4,2%), as well as the resource rent in production of coal (4,26%), and other mining activities (5,94%).

Aggregated production index rises by 0,57%. Agriculture production index rises by 0,08%. Extraction production stays constant on the level of the base year. Manufacturing production index rises by 0,91%, which indicates shift of the resources to manufacturing sector.

Services production index decreases by -0,42%. This is the consequence of decline in government spending, since government's demand drives total demand for services.

Structural changes induced by deterioration of the terms of trade lead to reallocation of mobile factors: workers change industries, as well as mobile capital. Though, the magnitude of reallocation is not significant: 0,66% of mobile capital changes sectors in the Central scenario, and 1,14% of workers.

5.3. Simulations results: steady-state model

The steady-state model is an extension of the comparative static model. The goal of the steady-state calculation is to evaluate the upper bound (Rutherford and Tarr 2003) on welfare changes associated with terms of trade deterioration for the Russian economy.

In the comparative static model the price of capital varies, while total supply of capital is fixed. In the steady-state model the mobile capital stock and investment demand are endogenously determined while the price of capital is constant. In other words, the steady-state model solves for time-invariant capital stock. In the steady-state model optimal capital stock is such that cost of investment equals the discounted stream of rents on installed capital⁷. "This can be viewed as a multi-sector version of the "golden rule" equilibrium" (Rutherford and Tarr 2003).

⁷ In the present version of the model depreciation is set to zero.

Major difference between the results of comparative static and steady-state models is captured in the changes of investment demand. As a result of deterioration of the terms of trade optimal capital stock for the economy decreases, causing investment demand to go down even further, then in the comparative static case. There is a -1,56% decrease in the total investment demand in the Central scenario of the steady-state model vs. decrease of -0,87% in the comparative static case.

The effects induced by the ToT deterioration on the capital stock echoes in total production index decreases. Thus, a decrease in the terms of trade pushes economy to an inferior steady state, characterized by decrease in the welfare of a representative consumer, lower level of production and consumption.

Overall economic impacts: steady-state model, Central scenario

Overall economic impacts for the Central scenario in the settings of the steady-state model are shown in the table below (Table 10). The results are presented for the Central scenario and its components.

Welfare changes associated with the Central scenario indicate a significant decrease in the welfare of the representative agent up to -2,46% of benchmark consumption level or -1,29% of the base year GDP. These results exceed welfare changes in the Central scenario of the static model, and we can refer to these values as upper bound of possible changes in welfare in the dynamic modelling exercise (Rutherford and Tarr 2003).

Percentage change of the GDP in the Central scenario of the steady-state model is of the same magnitude as representative agent's decrease in welfare in terms of the benchmark GDP: -2,51%.

The decline in the GDP is driven by decrease in government consumption (-5,21%). Private consumption decline (-2,46%) as well.

The external closure of the steady-state model is the same as in the static model, i.e. trade balance is fixed in real terms and the exchange rate adjusts to changes in relative prices of exported and imported goods. The exchange rate is defined in unites of local currency to units of foreign currency, thus an increase in the value of the exchange rate means depreciation of the local (domestic) currency. A decrease in the exchange rate means that domestic currency strengthens.

The Central scenario of the steady-state model is associated with a 4,3% increase in the exchange rate. This means that all imported goods are 4,02% more expensive than in the base year.

Numeraire of the steady-state model is consumer price index, thus CPI change in all scenarios equals to zero. Since only relative prices matters in the computable general equilibrium models, all other prices are quoted in terms of the numeraire (CPI in our case). Given that CPI is fixed, changes in the exchange rate reflect changes in the real exchange rate.

Representative agent's income comes from primary factors. In the central scenario of the steady-state model wages change by -2,6% and return to mobile capital by -0,08%.

Return to specific capital in extracting industries or natural rent, decreases for crude oil production (-4,02%), indicating reduction of production activities. All other extracting sectors feel much better with increase in return to specific capital in the Central scenario: the resource rent in production of natural gas rises (3,24%), as well as the resource rent in production of coal (3,36%), and other mining activities (5,14%).

Aggregated production index decreases by -0,347%. Agriculture production index increases insignificantly (by 0,03%), extraction production index decreases by -0,05%, manufacturing production index rises by 0,73%. This indicates shift of the resources to manufacturing sector, along the same lines, wish we saw in the static case. Though, increase in production of manufacturing doesn't outweigh decrease in all other parts of the economy, contrary to the result in the static model. Services production index decreases by -1,05%.

Structural changes induced by deterioration of the terms of trade lead to reallocation of mobile factors: workers change industries, as well as mobile capital. The magnitude of reallocation in the steady-state model is more significant than in the static one: 2% of mobile capital changes sectors in the Central scenario, and 1,2% of workers.

5.4. Changes on the industry level

Output changes

Changes on the industry level are presented in the Appendix (Table 9-Table 11). On the industry level we can trace the same tendencies that were obvious on the macro level: decrease in private consumption, decrease in imports, relative increase in exports and associated with export dynamics changes in production. Exporting becomes a profitable alternative to stagnating domestic market. Though, this doesn't lead to an export-led growth.

Industrial changes in the comparative static (Table 9) and steady-state (Table 11) models describe similar pictures but have important differences. Industrial output change

induced by the terms of trade deterioration depend on the cost structure of the industries, and changes in domestic demand. Magnitude of changes industry output are much bigger in the steady-state version of the model, and in the static one. Partially this reflects a much deeper restructuring of the economy under assumption of the steady-state model: reduction of installed capital, induced by the ToT change, and a much deeper decrease in imports lead to a bigger reallocation of factors, which was discussed above.

Price changes

Changes in prices on the industry level are presented in the Appendix (Table 13). Changes in prices of output, industry revenues, costs of manufactured intermediates and intermediates services in production are presented for the Central scenario of the static model. As it is evident in case of output changes on the industry level, we can trace the same tendencies that manifest themselves on the macro level: resulting prices on the industry level is a result of two main forces, decrease of domestic demand due to decrease of disposable income of the representative agent and increase in prices due to depreciation of the national currency.

The propagation of the exchange rate devaluation into production costs goes along the lines of the structure of the use of imported intermediates, as presented in the figure below (Figure 6).

Figure 6. Imports in intermediate consumption: darker cells correspond to higher share of imports in intermediate use by industry and by intermediate commodity group, benchmark dataset, 2011.



Source: author's calculations based on 2011 Russian input-output tables

From the figure above it is evident, that according to the data in the system of national accounts, the dependence of the Russian economy on imports is not industry-based, but can be described as product-based. There is evident tendency of all industries to consume more imported leather products (s019) and imported office electronics (s30) then domestic ones. As a consequence, pass through of exchange rate depreciation associated with terms of trade shock would be more in costs of those industries which use those intermediate goods relatively more than others.

An evidence of this tendency can be traced in changes of cost indices of production presented in Appendix (Table 13). Average change in costs of intermediates across all industries is 0.21. Imported services are almost absent from the intermediate consumption, there is no influence of exchange rate deterioration on the cost of intermediate services. So, a 4,3% increase in the real⁸ exchange rate corresponds to average increase of 0,2% in cost index of intermediate goods consumption.

⁸ Please note, that CPI is fixed as a numeraire in the Central scenario of the static model, thus real and nominal values of the exchange rate coincide.

5.5. Validation of the model: historical simulations

Validation of computable general equilibrium model is important and time-consuming process. There are different ways to assure validity of a computational models, and a CGE in particular. A computational model (Dixon and Rimmer 2013):

- (i) should be computationally sound. Computational quality of the present model is ensured by numerous checks, including replication of the benchmark dataset.
- (ii) should use accurate up-to-date data. As discussed earlier, the most up-to-date available data is used for the creation of the benchmark dataset.
- (iii) should adequately captures behavioural and institutional characteristics of the relevant part of the economy. A range of behavioural and institutional characteristics is used in the presented model based on the latest research on Russian economy.
- (iv) should be consistent with history. In order to validate model's consistency historical experiments were conducted. The setting of the experiments and results are discussed below.

A historical scenario is defined as changes in exogenous parameters of the model that were observed in the data. Validation of the model is done on the basis of goodness of fit of the detailed results to the historical values of endogenous variables of the model.

One of many possible measures of the goodness of fit is the “average error” measure proposed by (Dixon and Rimmer 2013):

$$AE = \left(\frac{1}{N}\right) * \sum_c |f_c - a_c| / \left(1 + \frac{a_c}{100}\right),$$

Where f_c - model forecast of the percentage change in the output of goods c ;
 a_c — statistics on change in output;
 N - the number of product groups in the model.

As a benchmark value for the average error of a detailed industrial historical scenario results (Dixon and Rimmer 2013) used average error calculated for the USAGE model, a detailed computable general equilibrium model for the American economy⁹. Benchmark value equals $AE = 19\%$ (Dixon and Rimmer 2013).

⁹ Detailed description of the USAGE model is available at <https://www.copsmodels.com/usage.htm>

The most important element of the historical simulation is correct assessment of changes in exogenous parameters of the model. In our case the most important exogenous parameters are world prices of exports and imports. The importance of these parameters for validation of the present model is based on the primary use of the model in estimation of the effect of the change in terms of trade for the Russian economy.

In order to calculate changes in export and import prices on the level of commodity groups, presented in the model, several datasets were used:

- 1) CEPII TUV dataset (Gaulier et al. 2010);
- 2) UN COMTRADE;
- 3) EAEU detailed trade data on 10-digit HS code level;
- 4) IMF Commodity price database;
- 5) IMF Commodity Terms of Trade (Gruss and Kebhaj 2019);
- 6) CBR database of main export prices of Russian exports.

Price data for exports and imports is highly volatile, and the most time-consuming effort is to exclude outliers from the data. The results of this process for the export price data are presented in table below (Table 3). Changes in import prices are presented in the Appendix (Table 7-Table 8).

Table 3. Changes in export prices to 2011 by commodity group

	<i>Change in export prices to 2011</i>				
	2012	2013	2014	2015	2016
01 Agriculture	101%	143%	-11%	-22%	-36%
02 Forestry	-2%	1%	-2%	-19%	-24%
05 Fishing	29%	49%	80%	84%	80%
10 Mining of coal	-5%	-19%	-27%	-41%	-50%
11101 Crude petroleum	5%	2%	-5%	-50%	-61%
11102 Natural gas	18%	10%	32%	9%	-35%
12 Mining of metal ores	50%	35%	38%	35%	26%
15 Food	54%	48%	42%	19%	18%
15 -9 Beverages	19%	14%	10%	-19%	-21%
16 Tobacco products	40%	45%	55%	39%	16%
17 Textiles	66%	62%	53%	32%	23%
18 Wearing apparel	19%	72%	-75%	-90%	-91%
19 Leather	49%	59%	65%	20%	23%
20 Wood products	3%	6%	35%	-24%	-19%
21 Paper products	55%	49%	52%	17%	8%
22 Publishing	93%	59%	100%	46%	39%
23 Refined petroleum	14%	-74%	-74%	-78%	-77%
24 Chemicals	-10%	-10%	-13%	-20%	-95%
25 Plastic products	24%	7%	-11%	-29%	-31%
26 Non-metallic products	40%	37%	66%	3%	-6%
27 Basic metals	16%	7%	0%	-19%	-17%

Source: author's estimates, UN COMTRADE, CEPII TUV databases

One of important characteristics of the historical response of the Russian economy on the changes in terms of trade that occurred in 2014-2015 was stable real output of the extraction sector. As we saw earlier this contradicts predictions of both static and steady-state models.

The simulations results presented in the table below (Table 4) suggest that behaviour of Russian oil and gas extraction sector is explained by changes in export taxes, which were almost cut by half at the same time when world prices fall, thus leaving the perceived dollar price of oil exports for firms in the industry almost unchanged. This situation is depicted in scenario #4. In a medium term time span, mimicked by 30% of all capital in the economy being specific, difference between model's forecast of output of oil and gas

sector and historical values, reported by Rosstat, equal to 0,4%. Further alternation of the model, including changes in the import prices, distort the results.

Table 4. Design and results of historical simulations.

	Model validation scenarios							
	#1	#2	#3	#4	#5	#6	#7	#8
Scenario design								
Change in export prices	*	*	*	*	*	*	*	*
Change in import prices	*		*		*			
Change in export taxes	*	*		*	*	*	*	*
Share of specific capital in all industries	0	0	0	30%	30%	50%	50%	50%
Share of specific capital in extraction	30%	30%	30%	30%	60%	50%	30%	70%
GTAP elasticities							*	*
Average error								
AE	17,6	19,8	20,0	16,4	20,3	17,3	17,3	20,4
Oil and gas output indicator								
Real output (% difference, model to statistics)	-1,98	0,53	-7,09	0,40	-4,96	-1,90	-1,90	-2,60

Source: Author's calculations

The results of the historical scenarios suggest that the presented computable general equilibrium model is valid for use of scenario estimation for the Russian economy. It could picture adequately diverse industrial response on terms of trade shocks.

Historical scenarios stress importance of fiscal changes in estimating changes in industry output at the time of terms of trade shocks, especially changes in export taxes in extraction industries.

6. Conclusion

This article examines the impact of changes in world prices on the Russian economy. In particular, I am interested in the change in production as a result of changes in world prices for the main Russian export and import commodities.

A number of recent macro studies ((Atalay 2017), (Acemoglu, Ozdaglar, and Tahbaz-salehi 2017) (Burstein, Kurz, and Tesar 2008)) stressed importance of explicit introduction of the intermediates in the models assessing effects of external shocks, which is a well-established practice in the computable general equilibrium methodology. Models of this class permit introduction of rich details and complex production structures as well as optimizing behaviour of economic agents.

The model presented in the paper belongs to the class of computable general equilibrium (CGE) models, it has a detailed industry structure, which allows tracing the effect of changes in world prices on all aspects of the Russian economy.

The results suggest a decrease of welfare of the representative consumer and real GDP with the deterioration of the terms of trade. In the Central scenario (a 10% decrease in the world price of crude oil, a 3% decrease in the world price of natural gas and an 8% decrease in the world price of petroleum products) welfare of the representative consumer decreases by -1,17% of benchmark consumption level or 0,58% of the base year GDP in the comparative static model. Percentage change of the GDP in the Central scenario of the comparative static model is of the same magnitude as representative agent's decrease in welfare in terms of the benchmark GDP: -1,55%.

Welfare changes associated with the Central scenario of the steady-state model indicate a significant decrease in the welfare of the representative agent up to -2,64% of benchmark consumption level or -1,23% of the base year GDP. Percentage change of the GDP in the Central scenario of the steady-state model exceeds representative agent's decrease in welfare in terms of the benchmark GDP: -2,51%. The GDP response in the steady-state model is in line with estimates obtained in compatible work (Полбин 2017).

These results exceed welfare changes in the Central scenario of the static model, and we can refer to these values as upper bound of possible changes in welfare in the dynamic modelling exercise (Rutherford and Tarr 2003).

References

- Acemoglu, Daron, Asuman Ozdaglar, and Alireza Tahbaz-salehi. 2017. "Microeconomic Origins of Macroeconomic Tail Risks." *American Economic Review* 107 (1): 54–108. <https://doi.org/10.1257/aer.20151086>.
- Aghion, Philippe, Philippe Bacchetta, and Abhijit Banerjee. 2000. "A Simple Model of Monetary Policy and Currency Crises." *European Economic Review* 44 (4–6): 728–38. [https://doi.org/10.1016/S0014-2921\(99\)00053-7](https://doi.org/10.1016/S0014-2921(99)00053-7).
- Aguiar, Angel, Badri Narayanan, and Robert McDougall. 2016. "An Overview of the GTAP 9 Data Base." *Journal of Global Economic Analysis* 1 (1): 181–208. <https://doi.org/10.21642/jgea.010103af>.
- Alekseev, Alexander, Denis Sokolov, Natalia Turdyeva, and Ksenia Yudaeva. 2004. "Estimating the Effects of EU Enlargement, WTO Accession and Formation of FTA with EU or CIS on Russian Economy." https://www.gtap.agecon.purdue.edu/resources/res_display.asp?RecordID=1485.
- Alekseev, Alexander, Natalia Turdyeva, and Ksenia Yudaeva. 2003. "Estimation of the Russia's Trade Policy Options with the Help of the Computable General Equilibrium Model. 1." Moscow.
- Armington, Paul S. 1969. "A Theory of Demand for Products Distinguished by Place of Production." Edited by I M F Workingpaper. *Staff Papers International Monetary Fund* 16 (1): 159–78. <https://doi.org/10.2307/3866403>.
- Arrow, K. J., H. B. Chenery, B. S. Minhas, and R. M. Solow. 1961. "Capital-Labor Substitution and Economic Efficiency." *The Review of Economics and Statistics* 43 (3): 225–50.
- Atalay, Engin. 2017. "How Important Are Sectoral Shocks?" *Online Appendix*. Vol. 9. <https://doi.org/10.1257/mac.20160353>.
- Baqae, David Rezza, and Emmanuel Farhi. 2019. "Productivity and Misallocation in General Equilibrium." <https://doi.org/10.3386/w24007>.
- Besstremyannaya, G.E., and A.R. Bakhtizin. 2006. "TAX POLICY MEASURES FOR EDUCATION AND HEALTHCARE SECTORS OF RUSSIAN ECONOMY: COMPUTABLE GENERAL EQUILIBRIUM ANALYSIS." 208. Препринт ЦЭМИ РАН. Москва. sp.lan.cemi-ras.ru/pub/Working_Papers/WP-208.pdf.
- Böhringer, Christoph, Thomas F. Rutherford, David G. Tarr, and Natalia Turdyeva. 2015. "Market Structure and the Environmental Implications of Trade Liberalization: Russia's Accession to the World Trade Organization." *Review of International Economics* 23 (5): 897–923. <https://doi.org/10.1111/roie.12197>.
- Burstein, Ariel, Christopher Kurz, and Linda Tesar. 2008. "Trade, Production Sharing, and the International Transmission of Business Cycles." 13731. *NBER Working Paper Series*. NBER Working Paper Series. <https://doi.org/10.1016/j.jmoneco.2008.03.004>.
- Bussolo, Maurizio, and Patrizia Luongo. 2017. "The Distributive Impact of Terms of Trade Shocks." *Policy Research Working Paper*, no. February: 1–35.
- Cavalcanti, Tiago V. De V., Kamiar Mohaddes, and Mehdi Raissi. 2015. "Commodity Price Volatility And The Sources Of Growth." *Journal of Applied Econometrics* 30 (6): 857–73. <https://doi.org/10.1002/jae>.
- Devarajan, Shantayanan, and Sherman Robinson. 2013. *Contribution of Computable General Equilibrium Modeling to Policy Formulation in Developing Countries. Handbook of Computable General Equilibrium Modeling*. Vol. 1. Elsevier. <https://doi.org/10.1016/B978-0-444-59568-3.00005-5>.
- Dixon, Peter B., Robert B. Koopman, and Maureen T. Rimmer. 2013. "The MONASH Style of Computable General Equilibrium Modeling: A Framework for Practical

- Policy Analysis." In *Handbook of Computable General Equilibrium Modeling*, Volume 1:23–103. <https://doi.org/http://dx.doi.org/10.1016/B978-0-444-59568-3.00002-X>.
- Dixon, Peter B., and Maureen T. Rimmer. 2013. *Validation in Computable General Equilibrium Modeling. Handbook of Computable General Equilibrium Modeling*. Vol. 1. Elsevier. <https://doi.org/10.1016/B978-0-444-59568-3.00019-5>.
- . 2016. "Johansen's Legacy to CGE Modelling: Originator and Guiding Light for 50 Years." *Journal of Policy Modeling* 38 (3): 421–35. <https://doi.org/10.1016/j.jpolmod.2016.02.009>.
- Dong, Baomin, Xili Ma, Ningjing Wang, and Weixian Wei. 2017. "Impacts of Exchange Rate Volatility and International Oil Price Shock on China's Regional Economy: A Dynamic CGE Analysis." *Energy Economics*. <https://doi.org/10.1016/j.eneco.2017.09.014>.
- Easterly, William, Robert King, Ross Levine, and Sergio Rebelo. 1994. "Policy, Technology Adoption and Growth." *Centre for Economic Policy Research Discussion Paper 957* (March): 15. <https://doi.org/10.3386/w4681>.
- Fehr, Hans. 2016. "CGE Modeling Social Security Reforms." *Journal of Policy Modeling* 38 (3): 475–94. <https://doi.org/10.1016/j.jpolmod.2016.02.007>.
- Fehr, Hans, Sabine Jokisch, Manuel Kallweit, Fabian Kindermann, and Laurence J. Kotlikoff. 2013. "Generational Policy and Aging in Closed and Open Dynamic General Equilibrium Models." In *Handbook of Computable General Equilibrium Modeling*, 1:1719–1800. <https://doi.org/10.1016/B978-0-444-59568-3.00027-4>.
- Gatti, Domenico Delli, Mauro Gallegati, Bruce C Greenwald, and Joseph E Stiglitz. 2007. "Net Worth, Exchange Rates, and Monetary Policy: The Effects of a Devaluation in a Financially Fragile Environment." 13244. *NBER Working Paper Series*. NBER Working Paper Series.
- Gaulier, Guillaume, Julien Martin, Isabelle Méjean, and Soledad Zignago. 2010. "International Trade Price Indices." 2010–23. *CEPII Working Paper*.
- Giesecke, James A, and John R Madden. 2013. *Chapter 7 - Regional Computable General Equilibrium Modeling. Handbook of Computable General Equilibrium Modeling*. Vol. Volume 1. Elsevier. <https://doi.org/http://dx.doi.org/10.1016/B978-0-444-59568-3.00007-9>.
- Greenwald, Bruce C., and Joseph E. Stiglitz. 1993. "Financial Market Imperfections and Business Cycles." *The Quarterly Journal of Economics* 108 (1): 77–114. <http://www.jstor.org/stable/2118496>.
- Gruss, Bertrand, and Suhaib Kebhaj. 2019. "Commodity Terms of Trade : A New Database." *IMF Working Paper*.
- Gylfason, T., and M. Schmid. 1983. "Does Devaluation Cause Stagflation?" *University of Stockholm, Institute for International Economic Studies, Reprint Series 224* (4): 641–54. <https://doi.org/10.2307/135045>.
- Helm, Carsten, and Thomas F. Rutherford. 2004. "Self-Enforcing Agreements and International Trade in Greenhouse Gas Emission Rights * Self-Enforcing Agreements and International Trade In." *Environmental and Resource Economics*, no. 919.
- Hertel, Thomas. 2013. "Global Applied General Equilibrium Analysis Using the Global Trade Analysis Project Framework." In *Handbook of Computable General Equilibrium Modeling*, edited by Kenneth J. Arrow and Michael D. Intriligator, 1:815–76. *Handbook of Computable General Equilibrium Modeling*. Elsevier. <https://doi.org/10.1016/B978-0-444-59568-3.00012-2>.
- Holmøy, Erling, and Birger Strøm. 2013. *Chapter 3 - Computable General Equilibrium Assessments of Fiscal Sustainability in Norway. Handbook of Computable General Equilibrium Modeling SET, Vols. 1A and 1B*. Vol. Volume 1.

- <https://doi.org/http://dx.doi.org/10.1016/B978-0-444-59568-3.00003-1>.
- Horridge, Mark, Alex Meeraus, Ken Pearson, and Thomas F. Rutherford. 2013. *Handbook of Computable General Equilibrium Modeling SET, Vols. 1A and 1B. Handbook of Computable General Equilibrium Modeling*. Vol. 1. Elsevier. <https://doi.org/10.1016/B978-0-444-59568-3.00020-1>.
- IMF. 2017. *Russian Federation*.
- International Monetary Fund. 2017. *World Economic Outlook: Gaining Momentum? World Economic Outlook April 2017*. Washington. www.imfbookstore.org.
- Jensen, Jesper, Thomas F. Rutherford, and David G. Tarr. 2004. "The Impact of Liberalizing Barriers to Foreign Direct Investment in Services: The Case of Russian Accession to the World Trade Organization." WPS3391. *World Bank Policy Research*. <https://doi.org/10.1017/CBO9781107415324.004>.
- Kolik, Alexander, Artur Radziwill, and Natalia Turdyeva. 2015. "Improving Transport Infrastructure in Russia." 1193. *OECD Economics Department Working Papers*. ECONOMICS DEPARTMENT WORKING PAPERS. Paris. <http://dx.doi.org/10.1787/5js4hmcs3mxc-en>.
- Kose, M. Ayhan. 2002. "Explaining Business Cycles in Small Open Economies." *Journal of International Economics* 56 (2): 299–327. [https://doi.org/10.1016/S0022-1996\(01\)00120-9](https://doi.org/10.1016/S0022-1996(01)00120-9).
- Lofgren, Hans, Marcelle Thomas, and Moataz El-said. 2002. *A Standard Computable General Equilibrium (CGE) Model in GAMS. Microcomputers in Policy Research*. Washington: International Food Policy Research Institute.
- Mathiesen, Lars. 1985. "Computation of Economic Equilibria by a Sequence of Linear Complementarity Problems." *Mathematical Programming Study* 23: 144–62.
- Mendoza, Enrique. 1995. "The Terms of Trade, the Real Exchange Rate, and Economic Fluctuations." *International Economic Review*. <https://doi.org/10.2307/2527429>.
- Nick, Sebastian, and Stefan Thoenes. 2014. "What Drives Natural Gas Prices? - A Structural VAR Approach." *Energy Economics* 45 (January 2009): 517–27. <https://doi.org/10.1016/j.eneco.2014.08.010>.
- Polanco Martínez, Josué M., Luis M. Abadie, and J. Fernández-Macho. 2018. "A Multi-Resolution and Multivariate Analysis of the Dynamic Relationships between Crude Oil and Petroleum-Product Prices." *Applied Energy* 228 (July): 1550–60. <https://doi.org/10.1016/j.apenergy.2018.07.021>.
- Pyatt, Graham. 1991. "Fundamentals of Social Accounting." *Economic Systems Research* 3 (3): 315–41. <https://doi.org/10.1080/09535319100000024>.
- Pyatt, Graham, and Jeffery I. Round. 1985. *Social Accounting Matrices: A Basis for Planning*. Edited by Graham Pyatt and Jeffery I. Round. Washington D.C.: The World Bank. <https://doi.org/10.4324/9781315301112-1>.
- Ramberg, David J., Y. H. Henry Chen, Sergey Paltsev, and John E. Parsons. 2017. "The Economic Viability of Gas-to-Liquids Technology and the Crude Oil–Natural Gas Price Relationship." *Energy Economics* 63: 13–21. <https://doi.org/10.1016/j.eneco.2017.01.017>.
- Reinsdorf, M. B. 2010. "Terms of Trade Effects: Theory and Measurement." *Review of Income and Wealth* 56 (1): S177–205. <https://doi.org/10.1111/j.1475-4991.2010.00384.x>.
- Rose, Adam, and Shu-Yi Liao. 2005. "Modeling Regional Economic Resilience to Disasters: A Computable General Equilibrium Analysis of Water Service Disruptions*." *Journal of Regional Science* 45 (1): 75–112. <https://doi.org/10.1111/j.0022-4146.2005.00365.x>.
- Rutherford, Thomas F., and Sergey Paltsev. 1999. "From an Input-Output Table to a General Equilibrium Model: Assessing the Excess Burden of Indirect Taxes in Russia." Department of Economics, University of Colorado.

- Rutherford, Thomas F., and David G. Tarr. 2004. "Algebraic Formulation of Services Liberalization Models," no. 1: 1–23.
<http://econ.worldbank.org/WBSITE/EXTERNAL/EXTDEC/EXTRESEARCH/EXTPROGRAMS/EXTTRADERESEARHC/0,,contentMDK:20273889~menuPK:544862~pagePK:64168182~piPK:64168060~theSitePK:544849~isCURL:Y~isCURL:Y~isCURL:Y~isCURL:Y,00.html>.
- Rutherford, Thomas F., and David G. Tarr. 2003. "Regional Trading Arrangements For Chile : Do The Results Differ With A Dynamic Model?" *Economie Internationale* 95: 261–82.
- Schmitt-Grohé, Stephanie, and Martín Uribe. 2018. "How Important Are Terms-of-Trade Shocks?" *International Economic Review* 59 (1): 85–111.
<https://doi.org/10.1111/iere.12263>.
- Shibusawa, Hiroyuki, Yuzuru Miyata, Hiroyuki Shibusawa, and Yuzuru Miyata. 2011. "EVALUATING THE DYNAMIC AND SPATIAL ECONOMIC IMPACTS OF AN EARTHQUAKE: A CGE APPLICATION TO JAPAN." *Regional Science Inquiry* III (2): 13–25.
- Tarr, David. 2006. "Regional Impacts of Russia ' s Accession to the WTO by and Regional Impacts of Russia ' s Accession to the WTO by Thomas Rutherford and David Tarr."
- Tarr, David G., and Thomas F. Rutherford. 2004. "Poverty Effects of Russia' s WTO Accession : Modeling 'Real' Households and Endogenous Productivity Effects." *Policy*.
- Tarr, David G., Oleksandr Shepotylo, and Timour Kouduyarov. 2005. "The Structure of Import Tariffs in Russia: 2001-2003." *International Relations*, 2001–3.
- Timilsina, Govinda R. 2015. *Oil Prices and the Global Economy: A General Equilibrium Analysis*. Energy Economics. Vol. 49. Elsevier B.V.
<https://doi.org/10.1016/j.eneco.2015.03.005>.
- Tokarick, Stephen. 2014. "A Method for Calculating Export Supply and Import Demand Elasticities." *Journal of International Trade and Economic Development* 23 (7): 1059–87. <https://doi.org/10.1080/09638199.2014.920403>.
- World Bank Group. 2015. *Russia Economic Report: Balancing Economic Adjustment and Transformation*. World Bank Group. Vol. 34.
- Zhang, Dayong, and Qiang Ji. 2018. "Further Evidence on the Debate of Oil-Gas Price Decoupling: A Long Memory Approach." *Energy Policy* 113 (August 2017): 68–75.
<https://doi.org/10.1016/j.enpol.2017.10.046>.
- Zodrow, George R., and John W. Diamond. 2013. *Chapter 11 – Dynamic Overlapping Generations Computable General Equilibrium Models and the Analysis of Tax Policy: The Diamond–Zodrow Model*. *Handbook of Computable General Equilibrium Modeling*. Vol. 1. <https://doi.org/10.1016/B978-0-444-59568-3.00011-0>.
- Алексеев, А. Н. Волчкова, И. Денисова, И. Левина, Н. Турдыева, and Ю. Халеева. 2004. "Микроэкономическая Оценка Последствий Налоговой Реформы Последствий Налоговой Реформы." 19. Аналитические Разработки и Отчеты. Москва. www.cefir.ru/download.php?id=468.
- Бадасен, П. В., Ф. С. Картаев, and А. А. Хазанов. 2015. "Эконометрическая Оценка Влияния Валютного Курса Рубля На Динамику Выпуска." *Деньги и Кредит*, no. 7: 41–49.
- Бахтизин, А. Р. 2003. "Вычислимая Модель 'Россия: Центр - Федеральные Округа.'" 151. Препринты ЦЭМИ РАН. Москва. sp.lan.cemir-ras.ru/pub/Working_Papers/WP-151.pdf.
- Березинская, О., and А. Ведев. 2015. "Производственная Зависимость Российской Промышленности От Импорта и Механизм Стратегического Импортозамещения." *Вопросы Экономики*, no. 1: 103–15.

- Вдовиченко, А., О. Дынникова, and В. Субботин. 2003. "О Влиянии Реального Обменного Курса На Различные Сектора Российской Экономики." *Экономическая Экспертная Группа*. Москва.
<http://www.eeg.ru/downloads/PUBLICATIONS/ANALYTICS/a20030828.pdf>.
- Волчкова, Наталья, Екатерина Горшкова, Сергей Лобанов, Алексей Макрушин, Наталья Турдыева, and Юлия Халеева. 2006. "Оценка Последствий Реформирования Системы Социальных Гарантий: Монетизация Ция Льгот и Реформа ЖКХ." 25. Аналитические Разработки и Отчеты. Москва.
<http://cefir.ru/download.php?id=469>.
- Дынникова, О. В. 2000. "Макроэкономические Перспективы Укрепления Рубля и Валютная Политика." *Экономическая Экспертная Группа*. Москва: ЭЭГ.
www.eeg.ru/downloads/BOOK/b05.pdf.
- Земницкий, А.В. 2003. "Оценка Последствий Устранения Нетарифных Барьеров Для Иностранских Компаний в Секторе Услуг Российской Экономики: Структурный Подход." 35. Научные Труды ЦЭФИР и РЭШ. Москва.
<http://www.cefir.ru/download.php?id=76>.
- Идрисов, Г. И., Ю. Ю. Пономарев, and С.Г. Синельников-Мурылёв. 2015. "Условия Торговли и Экономическое Развитие Современной России." *Экономическая Политика* 10 (3): 7–37. <https://doi.org/10.18288/1994-5124-2015-3-01>.
- Кадочников, Павел Анатольевич, Сергей Германович Синельников-Мурылёв, and Сергей Николаевич Четвериков. 2003. *Импортозамещение в Российской Федерации в 1998-2002 Гг. Институт Экономики Переходного Периода*. Научные тр. Москва: Институт Экономики Переходного Периода.
<https://www.iep.ru/ru/publikacii/publication/34.html>.
- Картаев, Ф. С. 2009. "Эконометрическое Моделирование Взаимосвязи Курса Рубля и Динамики ВВП." *Вестник Московского Университета*, no. 2: 57–67.
- Конторович, В.К. 2001. "Взаимосвязь Реального Курса Рубля и Динамики Промышленного Производства в России." *Экономический Журнал ВШЭ*, no. №3: 363–74.
- Макаров, В. Л. 1999. "Вычислимая Модель Российской Экономики (RUSEC)." 99/069. Препринт ЦЭМИ. Москва.
- Полбин, Андрей Владимирович. 2017. "Оценка Влияния Шоков Нефтяных Цен На Российскую Экономику в Векторной Модели Коррекции Ошибок План Презентации." *Вопросы Экономики*, no. 10: 27–49.
- Росстат. 2017. *Национальные Счета России в 2011-2016 Годах: Статистический Сборник*. Москва: Росстат.

Appendix I. Analytical structure of the model

I follow notation developed in (Jensen, Rutherford, and Tarr 2004) in the description of the analytical structure of the model.

Equations

Household's problem

The representative household is maximizing Cobb-Douglas utility (1) subject to budget constraint (2).

$U(C) = \sum_i \theta_i \log(c_i)$	(1)
------------------------------------	-----

Where c_i - good i consumption by a representative agent, $i=1,n$;

$C = (c_1, \dots, c_i, \dots, c_n)$ – consumption basket $i=1,n$ of the representative household;

θ_i – Cobb-Douglas function exponent coefficient, calibrated to the cost share of the product i in the total cost of consumption of basket C ;

$U(C)$ – utility function of a representative household.

Representative household's budget accounts for sales taxes t_i^c and fixed trade and transport margins ($\tau_{ki}p_k$):

$(1 + t_i^c)p_i c_i + \sum_k \tau_{ki} p_k = N$	(2)
---	-----

Where, N - representative agent's disposable budget;

τ_{ki} – share of mark-ups of type k in costs of supplying Armington mix of good i to a market, $k \in (\text{transport, trade})$.

Representative agent's income is defined as the sum of factor returns less direct taxes:

$N = wL + r_K K + \sum_i r_i^s K_i^s - T_{LS}$	(3)
--	-----

where w - wage;

L – labour supply;

r_K - mobile capital rent;

K – mobile capital supply;

r_i^s – specific capital rent in extraction industries coal, oil, natural gas, other extraction industries;

K_i^s - stock of specific factor in industry i ,

T_{LS} - direct taxes.

Government and investment demands in the core model assumed to be fixed on the base year level.

Government budget

The state collects a number of indirect and direct taxes. These taxes and related ad-valorem rates include taxes on production (t_i^y), taxes on intermediate consumption (t_{ij}^a), taxes on imports (t_i^M), taxes on government procurement (t_i^G), taxes on investment demand (t_i^I), taxes on exports (t_i^X) and taxes on household's consumption (t_i^C). The state budget:

$$\sum_i (1 + t_i^G) p_i a_i^G = T_Y + T_a + T_M + T_G + T_I + T_X + T_C + T_{FS} + T_{LS} \quad (4)$$

Where

T_k – revenue from a tax k ;

T_{FS} – revenue from taxes on factors of production;

T_{LS} – revenue from direct taxes.

It is assumed in the core model that government consumption is fixed in real terms in the core government sector's demand is fixed on the base year level: $a_i^G = \bar{G}_i$. Adjustment of the implicit savings of a representative agent compensates for changes in cost of government consumption due to changes in prices and tax revenues.

Supply for domestic and export markets

Domestically produced goods and services supplied to domestic and international markets. A constant elasticity of transformation (CET) function describes transformation possibilities between domestic (d_i) and export (e_i) supplies of domestic output (Y_i). Sales shares in the country and abroad are determined by relative prices, provided that firms produce final goods in order to minimize cost subject to CET production function:

$$Y_i = \bar{Y}_i \left[\theta_D \left(\frac{d_i}{\bar{D}_i} \right)^{\frac{1+\eta}{\eta}} + (1 - \theta_D) \left(\frac{e_i}{\bar{E}_i} \right)^{\frac{1+\eta}{\eta}} \right]^{\frac{\eta}{1+\eta}} \quad (5)$$

In this equation, the parameters are:

base year supply for domestic market (\bar{D}_i)

and export (\bar{E}_i) markets,

level of the base year production \bar{Y} ,

θ_D – the share parameter of the CET function, calibrated to domestic sales in total sales of the base year,

and η – elasticity of transformation between supply to domestic and export markets.

Associated cost function, i.e. the cost of supply of sector i in the domestic and export market is denoted by $CET(p_i^D, p_i^X)$.

Production technology is described by the nested Leontief production function: output depends on the volume of consumption of intermediate goods, a_{mi} , (where $m=1, n$) and primary factors of production, mobile labor L_i and capital K_i , and specific K_i^S capital.

Producers demand intermediate goods and factors in order to minimize production costs for a given volume of products under the technological constraint (production function):

$Y_i = \bar{Y}_i \min [a_{mi}, VA_i(L_i, K_i, K_i^S)]$	(6)
--	-----

where $a_{mi} = (a_{m1,i}, a_{m2,i}, \dots)$ – intermediate goods used in production of good i .

$VA_i(L_i, K_i, K_i^S)$ – value added, a Cobb-Douglas mixture of primary factors.

Balance of payments

In the main version of the model, the current account balance is fixed in real terms on the level of the base year. Current account is the difference between value of exports and imports

\bar{p}_i^X – exogenous world export prices;

e_i – volume of exports (in real terms);

\bar{p}_i^M – exogenous world prices for imported goods;

m_i – volume of imports (in real terms).

The increase (decrease) in imports should be compensated by a corresponding reduction (increase) in exports, while maintaining a fixed surplus of the current account at the level of the base year (\bar{V})

$\sum \bar{p}_i^X e_i = \sum \bar{p}_i^M m_i + \bar{V} \perp \rho$	(7)
--	-----

Following work of Lars Mathiesen (Mathiesen 1985), which show that the Arrow – Debreu equilibrium can be formulated and solved as a sequence of complementary problems, the arbitrage and market clearing conditions are presented in the complementary slackness format.

The balance of payments constrains is the market equilibrium constraint that has exchange rate as a complimentary variable (ρ).

Arbitrage conditions

Production of a good i would take place if equation (8) holds, or in terms of complementary slackness formulation: (8) $\perp Y_i$.

The cost of supply of sector i in the domestic and export market $CET(p_i^D, p_i^X)$ is equal to the cost of production $COST^Y(p_{ij}^m, p_i, w, r_K, r_i^S)$. Primary factors of production and intermediates

are connected in a nested production function with a constant elasticity of substitution (CES) $COST^Y(p_{ij}^m, p_i, w, r_K, r_i^S)$ which includes:

- intermediate goods (price of intermediate goods j used in the production of good i (p_{ij}^m);
- price of bundled services for intermediate and final consumption p_i^S
- labour (wage - w);
- mobile capital (mobile capital rent - r_K)
- and specific capital (specific capital rent - r_i^S):

$Y_i \perp CET^Y(p_i^D, p_i^X) = COSTS^Y(p_{ij}^m, p_i, w, r_K, r_i^S)$	(8)
---	-----

Where p_i^D – price of a domestically produced good i for domestic market ;

p_i^X – domestic price of a good i for the export market.

$\perp a_i$ Bundling of domestic and imported goods for different markets:

Price of goods (p_i) reflects the cost $CES^A(p_i^D, p_i^M)$ of domestic (p_i^D) and imported resources (p_i^M), as well as the associated trade and transport margins (p_k):

$a_i \perp p_i = CES^A(p_i^D, p_i^M) + \sum_k \tau_{ki} p_k$	(9)
--	-----

Where τ_{ki} - share of mark-ups of type k in costs of supplying Armington mix (a bundle of domestic and imported goods) of good i to a market (differs for each separate market: for final consumption of households, government, investment, and intermediate goods' markets).

Two bundling processes are described by (9): aggregation on the industry and product level of intermediate goods, and bundling of intermediate services and goods for final consumption by households, government and investment sector.

Intermediate consumption of goods (a_{ij}^m) priced (p_{ij}^m), for intermediate consumption of industry i of good j. Note that services are not aggregated this way – firms in the industry demand services for intermediate consumption on the final market. The equation below is presented with an associated complementarity condition:

$a_{ij}^m \perp p_{ij}^m = CES_{ij}^m(p_j^D, p_j^M) + \sum_k \tau_{ki} p_k$;	(9-a)
---	-------

Where $CES_{ij}^m(p_j^D, p_j^M)$ – cost of supplying a bundle of domestic and imported intermediate goods.

Intermediate consumption of services (a_i^S) priced (p_i), with an associated complementarity condition:

$a_i^S \perp p_i = CES^A(p_i^D, p_i^M) + \sum_k \tau_{ki} p_k, \quad \text{for } i \in \{\text{services}\}$	(9-b)
---	-------

$\perp e_i$ Domestic price of exports is equal to the exogenous (FOB) price of the world market (expressed in the world currency) (\bar{p}_i^X), multiplied by the exchange rate (ρ):

$e_i \perp p_i^X = \bar{p}_i^X \cdot \rho$	(10)
--	------

$\perp m_i$ Domestic price of imports is equal to the exogenous (CIF) price of the world market (expressed in foreign currency) \bar{p}_i^M , multiplied by the exchange rate (ρ):

$m_i \perp p_i^M = \bar{p}_i^M \cdot \rho$	(11)
--	------

Free entry guarantees zero profit in all industries. This means that gross income is equal to the sum of all production costs.

Market equilibrium conditions

$\perp p_i$ Commodity markets: aggregate supply is equal to aggregate demand on each market:

$a_i = c_i + a_i^I + a_i^G + \sum_j a_{ij}^S \perp p_i,$	(12)
$a_{ij}^S = Y_i \cdot \frac{\partial \text{COST}_i^y}{\partial p_j}, j \in \{\text{services}\}$	

in the core model investment sector's demand is fixed on the base year level: $a_i^I = \bar{I}_i$; government sector's demand is fixed on the base year level: $a_i^G = \bar{G}_i$; This formulation of demand utilizes Shephard's lemma, stating that conditional factor demand for each input factor is the derivative of the cost function.

$\perp p_{ij}^m$ Supply of intermediate goods equals demand

$a_{ij}^m = Y_i \cdot \frac{\partial \text{COST}_i^y}{\partial p_{ij}^m} \perp p_{ij}^m$	(13)
--	------

$\perp p_i^D$ Domestic goods markets: the supply of domestic goods equals to the demand for domestically produced goods and services from all markets:

$d_i = \sum_j a_{ij}^m \frac{\partial \text{CES}_{ij}^m(p_j^D, p_j^M)}{\partial p_j^D} + a_i \frac{\partial \text{CES}^A(p_i^D, p_i^M)}{\partial p_i^D}$	(14)
--	------

$\perp p_i^M$ Import markets: total imports include sales of aggregate demand plus sales to firms for intermediate consumption:

$m_i = \sum_j a_{ij}^m \frac{\partial \text{CES}_{ij}^m(p_j^D, p_j^M)}{\partial p_j^M} + a_i \frac{\partial \text{CES}^A(p_i^D, p_i^M)}{\partial p_i^M}$	(15)
--	------

$\perp w_\ell$ The supply of labor is equal to the demand for labor:

$\bar{L} = \sum_i y_i \frac{\partial \text{COST}_i^y}{\partial w_\ell}$	(16)
---	------

Where \bar{L} - total supply of labour, fixed on the level of the base year;

$\perp r_K$ Capital supply equals demand for capital:

$$\bar{K} = \sum_i y_i \frac{\partial \text{COST}_i^Y}{\partial r_K} \quad (17)$$

Where \bar{K} – total supply of mobile capital, fixed on the level of the base year (core model formulation);

$\perp r_i^S$ The supply of firm-specific capital equals the demand for specific capital by the firm i :

$$K_i^S = a_i \frac{\partial \text{CES}_i^A}{\partial r_i^S} \quad (18)$$

Where K_i^S – fixed supply of specific capital in industry i .

Symbol map

Table 5. Symbols used in the analytical description of the model

	Symbol	Definition (in the order of appearance in the Appendix I)
1	\bar{D}_i	benchmark production for domestic market of good i , where $i=1,n$
2	\bar{E}_i	benchmark exports of good i , where $i=1,n$
3	\bar{G}_i	the base year government demand
4	\bar{I}_i	the base year investment demand
5	\bar{p}_i^M	exogenous world prices for imported goods
6	\bar{p}_i^X	exogenous world export prices
7	\bar{Y}_i	domestic output of good i in the benchmark equilibrium of the base year, where $i=1,n$
8	a_i^G	government consumption of good i
9	a_i^S	Armington mix of services (domestic and import bundle) for final and intermediate consumption
10	a_i	supply of an Armington mix (a bundle of domestic and imported goods) for final markets (household, government and investment)
11	a_{ij}^m	Armington mix of goods (domestic and import bundle) for intermediate consumption
12	c_i	good i consumption by a representative agent, $i=1,n$;
13	$\text{CES}_{ij}^m(p_j^D, p_j^M)$	cost of supplying a bundle of domestic and imported intermediate goods j to industry i
14	$\text{COST}_i^Y(p_{ij}^m, p_i^S, w, r_K, r_i^S)$	cost of production of good Y_i with a nested production function
15	d_i	supplies of good i for the domestic market, where $i=1,n$
16	e_i	exports of good i , where $i=1,n$
17	K_i^S	stock of specific factor in industry i
18	\bar{K}	mobile capital supply
19	\bar{L}	labour supply

	Symbol	Definition (in the order of appearance in the Appendix I)
20	m_i	volume of imports (in real terms)
21	p^G	price index on government procurement
22	p_i^D	price of a domestically produced good i for domestic market
23	p_i^M	domestic price of imports
24	p_i^X	domestic price of a good i for the export market
25	p_i	price of a good (Armington bundle of domestic and imported goods) i on the final goods' market (final goods and services are consumed by households, government and investment sector), where $i=1,n$
26	p_{ij}^m	price of intermediate goods
27	p_k	Price of service k , used for supplying goods to markets (transport or trade services)
28	r_i^S	specific capital rent in extraction industries coal (s10), oil, natural gas, other extraction industries (s12x);
29	r_K	rent
30	T_a	revenue from taxes on intermediate consumption t_{ij}^a
31	T_C	revenue from taxes on household's consumption t_i^C
32	T_{FS}	revenue from taxes on factors of production
33	T_G	revenue from taxes on government procurement t_i^G
34	t_i^C	sales tax rates on good i , where $i=1,n$
35	T_I	revenue from taxes on investment demand t_i^I
36	T_{LS}	direct taxes
37	T_M	revenue from taxes on imports t_i^M
38	T_X	revenue from taxes on exports t_i^X
39	T_Y	revenue from taxes on production t_i^Y
40	\bar{V}	fixed surplus of the current account at the level of the base year a
41	Y_i	domestic output of good i , where $i=1,n$
42	θ_D	the share parameter of the CET function, calibrated to domestic sales in total sales of the base year
43	θ_i	Cobb-Douglas function exponent coefficient, equal to the cost share of the product i in the total cost of consumption of basket C ;
44	τ_{ki}	share of mark-ups of type k in costs of supplying Armington mix of good i to a market
45	$C = (c_1, \dots, c_n)$	consumption basket $i=1,n$ of the representative household;
46	$CES^A(p_i^D, p_i^M)$	cost of producing an Armington mix of domestic and imported goods for final (household, government and investment consumption) and intermediate markets
47	$CET(p_i^D, p_i^X)$	cost of production of good d_i for domestic market and good e_i for the export market with a CET production function
48	N	representative agent's income
49	$U(C)$	utility function of a representative household
50	VA_i	$VA_i(L_i, K_i, K_i^S)$ – value added, a Cobb-Douglas mixture of primary factors
51	w	wage

	Symbol	Definition (in the order of appearance in the Appendix I)
52	η	elasticity of transformation between supply to domestic and export markets
53	ρ	exchange rate (in terms of units of local currency to a unit of foreign currency used for pricing of the country's exports and imports)
54	η	elasticity of transformation between supply to domestic and export markets
55	σ^m	elasticity of substitution between domestic and imported goods in intermediate consumption
56	σ^Y	elasticity of substitution between value added and intermediate goods in the production function
57	σ^{VA}	elasticity of substitution between different factors in production of value added
58	σ^A	elasticity of substitution between domestic and imported goods in the Armington aggregation function for production of final goods

Appendix II Data and parametrization

Industry list

Table 6. Activities and commodity groups presented in the model

#	Code	Short name of activity / commodity group
1	s01	Agriculture
2	s02	Logging
3	s05	Fishery
4	s10	Coal and peat
5	oil	Crude oil
6	gas	Natural gas
7	s112	Services related to oil and gas prod.
8	s12x	Other minerals
9	s15	Food products
10	s15x	Beverages
11	s16	Tobacco products
12	s17	Textile products
13	s18	Clothes and fur
14	s19	Leather products
15	s20	Wood
16	s21	Paper
17	s22	Publishing and printing
18	s23	Coke and petrochemical products
19	s24	Chemical products
20	s25	Rubber and plastic products
21	s26	Other non-metallic mineral products
22	s27	Metals
23	s28	Finished metal products
24	s29	Machinery and equipment
25	s30	Office equipment and computers
26	s31	Electrical machinery
27	s32	Radio, television and communication equipment
28	s33	Precision and optical instruments
29	s34	Motor vehicles
30	s35	Other transport equipment

#	Code	Short name of activity / commodity group
31	s36x	Furniture, recycling
32	s40	Power supply, steam and hot water
33	s41	Collection and distribution of water
34	s45	Construction
35	trd	Trade
36	s55	Hotels and restaurants
37	trn	Transport
38	s63	Auxiliary modes of transport
39	s64	Post and telecommunications
40	s65x	Financial intermediation and insurance
41	s70	Real estate activities
42	s71	Rent of machinery and equipment
43	s72	Computer and related activities
44	s73	Research and development
45	s74	Other business services
46	s75	Public administration and defense
47	s80	Education
48	s85	Health and social work
49	s90	Sanitation and waste management
50	s91	Activities of membership organizations
51	s92	Recreational cultural and sporting events
52	s93x	Other activities, domestic work

Source: author

Appendix III Simulations design

Table 7. Changes in import prices to 2011 by commodity group, part 1

	<i>Change in import prices to 2011</i>				
	2012	2013	2014	2015	2016
01 Agriculture	-9%	-25%	-6%	-21%	-18%
02 Forestry	2%	13%	-2%	3%	-11%
05 Fishing	-1%	12%	17%	-68%	-66%
10 Mining of coal	37%	33%	-44%	-53%	-63%
15 Food	9%	12%	11%	-20%	-24%
15 -9 Beverages	0%	8%	-3%	-24%	-25%
16 Tobacco products	-6%	1%	-7%	-12%	-20%
17 Textiles	17%	16%	19%	9%	12%
18 Wearing apparel	23%	32%	34%	22%	21%
19 Leather	4%	11%	21%	23%	36%
20 Wood products	56%	60%	76%	34%	24%
21 Paper products	11%	4%	-1%	-16%	-17%

Source: author's estimates, COMTRADE, CEPII TUV databases

Table 8. Changes in import prices to 2011 by commodity group, part 2

	<i>Change in import prices to 2011</i>				
	2012	2013	2014	2015	2016
22 Publishing	2%	8%	-10%	2%	11%
23 Refined petroleum	55%	87%	37%	50%	48%
24 Chemicals	-4%	-1%	-8%	-33%	-30%
25 Plastic products	8%	0%	2%	-9%	-6%
26 Non-metallic products	22%	33%	19%	16%	22%
28 Metal products	54%	51%	26%	12%	13%
29 Machinery	6%	8%	8%	0%	2%
30 Office machinery	-6%	15%	21%	22%	27%
31 Electrical machinery	14%	14%	10%	3%	0%
32 Radio television	0%	0%	0%	0%	0%
33 Medical instruments	1%	6%	4%	-15%	-13%
34 Motor vehicles	0%	4%	-3%	-22%	-17%

Source: Author's estimates, COMTRADE, CEPII TUV databases

Appendix IV Simulation results

Table 9. Impact of the terms of trade shock in the Central scenario and its components, static model, results are percentage changes from the base year

	Central scenario	Oil scenario	Natural gas scenario	Petroleum products scenario
World price change				
Crude oil	-10%	-10%		
Natural gas	-3%		-3%	
Petroleum products	-8%			-8%
Aggregate welfare				
Welfare (EV as % of consumption)	-1,169	-0,681	-0,099	-0,387
Welfare (EV as % of GDP)	-0,577	-0,335	-0,048	-0,189
GDP decomposition				
GDP (% change)	-1,545	-0,989	-0,095	-0,440
Real private consumption (C % change)	-1,169	-0,681	-0,099	-0,387
Real government consumption (G % change)	-4,277	-2,942	-0,178	-1,052
Real investment demand (I % change)	-0,874	-0,543	-0,060	-0,263
Real aggregated exports (E % change)	1,226	0,887	-0,005	0,288
Real aggregated imports (M % change)	-5,384	-3,262	-0,498	-1,667
RER and CPI				
Real exchange rate (% change)	4,236	2,538	0,376	1,208
Consumer price index (% change)	0,000	0,000	0,000	0,000
Return to primary factors				
Labor (w % change)	-1,333	-0,836	-0,113	-0,372
Mobile capital (r % change)	-0,726	-0,371	-0,072	-0,282
Crude oil resources (% change)	-3,222	-2,589	0,468	-1,075
Natural gas resources (% change)	4,196	5,978	-3,885	2,631
Coal resources (% change)	4,264	2,689	0,452	0,966
Other mining resources (% change)	5,937	3,561	0,568	1,619
Aggregated production				
Aggregated production index (% change)	0,569	0,363	0,059	0,134
Agriculture production index (% change)	0,080	0,048	0,010	0,023
Extraction production index (% change)	0,004	-0,008	0,012	0,001
Manufacturing production index (% change)	0,907	0,568	0,109	0,207
Services production index (% change)	-0,422	-0,245	-0,072	-0,096
Factor adjustment				
Mobile capital (% changing sectors)	0,657	0,435	0,124	0,207
Labor (% changing sectors)	1,138	0,772	0,102	0,301

Source: author's estimates

Table 10. Impact of the terms of trade shock in the Central scenario and its components, stationary model, results are percentage changes from the base year

	Central scenario	Oil scenario	Natural gas scenario	Petroleum products scenario
World price change				
Crude oil	-10%	-10%		
Natural gas	-3%		-3%	
Petroleum products	-8%			-8%
Aggregate welfare				
Welfare (EV as % of consumption)	-2,464	-1,412	-0,227	-0,868
Welfare (EV as % of GDP)	-1,229	-0,697	-0,111	-0,425
GDP decomposition				
GDP (% change)	-2,510	-1,532	-0,190	-0,797
Real private consumption (C % change)	-2,464	-1,412	-0,227	-0,868
Real government consumption (G % change)	-5,213	-3,465	-0,269	-1,394
Real investment demand (I % change)	-1,562	-0,931	-0,128	-0,517
Real aggregated exports (E % change)	0,427	0,438	-0,083	-0,005
Real aggregated imports (M % change)	-6,506	-3,907	-0,614	-2,097
RER and CPI				
Real exchange rate (% change)	4,301	2,574	0,382	1,230
Consumer price index (% change)	0,000	0,000	0,000	0,000
Return to primary factors				
Labor (w % change)	-2,609	-1,555	-0,239	-0,845
Mobile capital (r % change)	-0,076	-0,007	-0,008	-0,044
Crude oil resources (% change)	-4,024	-3,046	0,386	-1,379
Natural gas resources (% change)	3,241	5,441	-3,972	2,287
Coal resources (% change)	3,365	2,188	0,366	0,642
Other mining resources (% change)	5,142	3,124	0,494	1,337
Aggregated production				
Aggregated production index (% change)	-0,347	-0,150	-0,030	-0,201
Agriculture production index (% change)	0,029	0,020	0,005	0,004
Extraction production index (% change)	-0,056	-0,042	0,006	-0,021
Manufacturing production index (% change)	0,730	0,469	0,092	0,143
Services production index (% change)	-1,050	-0,597	-0,133	-0,327
Factor adjustment				
Mobile capital (% changing sectors)	2,007	1,167	0,241	0,704
Labor (% changing sectors)	1,284	0,855	0,113	0,349

Source: author's estimates

Table 11. Changes in real production, exports, imports and household's consumption in the Central scenario, comparative static model

Short name of activity / commodity group	Change in production	Change in exports	Change in imports	Change in HH consumption
Agriculture	2,10	2,90	-9,54	-1,15
Logging	1,58	2,51	-0,55	-0,26
Fishery	1,28	1,70	-3,73	-2,10
Coal and peat	3,64	4,33	-1,09	0,39
Crude oil	-1,74	-2,29	-10,39	
Natural gas	3,55	2,88	-6,70	
Services related to oil and gas prod.	0,37	0,94	-10,21	-5,19
Other minerals	4,82	5,13	2,62	-1,32
Food products	1,70	2,45	-9,48	-0,99
Beverages	1,68	2,46	-13,79	-0,84
Tobacco products	-0,52	0,16	-9,80	-0,93
Textile products	6,91	7,51	-3,39	-2,07
Clothes and fur	7,97	8,64	-5,06	-1,84
Leather products	19,32	19,58	-4,65	-2,28
Wood	3,01	3,84	-5,19	-0,05
Paper	2,76	3,48	-2,03	-1,51
Publishing and printing	-0,08	1,10	-9,55	-0,90
Coke and petrochemical products	-0,63	-1,70	-6,06	-5,71
Chemical products	7,42	7,06	-3,28	-1,67
Rubber and plastic products	2,82	3,62	-1,53	-1,60
Other non-metallic mineral products	0,62	1,42	-2,74	-1,22
Metals	5,21	6,05	-3,11	0,87
Finished metal products	3,56	4,63	-3,03	-1,63
Machinery and equipment	8,55	9,05	-5,22	-2,06
Office equipment and computers	10,63	9,80	-1,99	-3,00
Electrical machinery	5,65	6,45	-3,06	-1,72
Radio, television and communication equipment	8,32	7,74	-2,97	-1,99
Precision and optical instruments	8,17	6,88	-7,95	-1,88
Motor vehicles	4,59	5,24	-5,13	-2,75
Other transport equipment	9,46	9,40	-14,06	-1,55
Furniture, recycling	6,87	7,48	-12,26	-1,33
Power supply, steam and hot water	0,58	1,45	-4,81	0,10
Collection and distribution of water	0,23	0,97	-5,92	0,01
Construction	-0,59	0,19	-14,44	-0,55
Trade	0,02	0,91	-18,23	-0,39
Hotels and restaurants	-1,05	-0,20		-0,72
Transport	0,57	1,09	-17,08	-0,85
Auxiliary modes of transport	0,42	1,15		-0,27
Post and telecommunications	-0,62	0,08		-0,58
Financial intermediation and insurance	0,70	1,45	-18,60	-0,24
Real estate activities	-0,37	0,44	-18,17	-0,41
Rent of machinery and equipment	1,14	1,80	-18,29	-0,37
Computer and related activities	-0,22	0,46	-17,23	-0,32
Research and development	-1,25	-0,15	-18,26	
Other business services	0,82	1,29	-20,82	0,29
Public administration and defense	-3,95	-3,24		-0,43
Education	-3,63	-2,83	-18,79	-0,16
Health and social work	-3,61	-2,87	-17,85	-0,54
Sanitation and waste management	-2,55	-0,77		-0,78
Activities of membership organizations	-3,94			-0,31
Recreational cultural and sporting events	-1,84	-1,09	-15,75	-0,44
Other activities, domestic work	-0,20			-0,05

Source: author's estimates

Table 12. Changes in production, exports, imports and household's consumption in the Central scenario, steady-state model

Short name of activity / commodity group	Change in production	Change in exports	Change in imports	Change in HH consumption
Agriculture	0,77	1,54	-10,49	-2,55
Logging	0,78	1,73	-1,52	-1,47
Fishery	0,09	0,52	-5,02	-3,36
Coal and peat	2,99	3,71	-2,03	-0,70
Crude oil	-2,67	-3,22	-11,26	
Natural gas	2,73	2,06	-7,73	
Services related to oil and gas prod.	-0,34	0,25	-11,52	-6,49
Other minerals	4,31	4,65	1,91	-2,52
Food products	0,46	1,22	-10,75	-2,28
Beverages	0,49	1,28	-15,26	-2,10
Tobacco products	-1,88	-1,22	-10,81	-2,30
Textile products	6,28	6,91	-4,64	-3,33
Clothes and fur	7,26	7,96	-6,41	-3,12
Leather products	19,25	19,53	-6,02	-3,56
Wood	2,26	3,13	-6,28	-1,22
Paper	1,76	2,49	-3,17	-2,78
Publishing and printing	-1,00	0,22	-11,14	-2,08
Coke and petrochemical products	-1,59	-2,67	-6,84	-7,10
Chemical products	6,60	6,25	-4,28	-2,96
Rubber and plastic products	2,04	2,88	-2,48	-2,84
Other non-metallic mineral products	-0,13	0,72	-3,73	-2,42
Metals	4,73	5,58	-3,81	-0,35
Finished metal products	3,01	4,14	-4,05	-2,83
Machinery and equipment	8,42	8,96	-6,36	-3,28
Office equipment and computers	10,53	9,63	-2,91	-4,28
Electrical machinery	5,29	6,13	-3,98	-2,95
Radio, television and communication equipment	8,10	7,50	-3,97	-3,21
Precision and optical instruments	8,27	6,87	-9,36	-3,05
Motor vehicles	4,01	4,70	-6,27	-3,98
Other transport equipment	9,68	9,63	-16,01	-2,67
Furniture, recycling	6,27	6,91	-13,75	-2,56
Power supply, steam and hot water	-0,34	0,57	-5,81	-1,02
Collection and distribution of water	-0,54	0,22	-7,06	-0,74
Construction	-1,32	-0,52	-15,48	-1,75
Trade	-1,03	-0,13	-19,52	-1,69
Hotels and restaurants	-2,24	-1,36		-1,96
Transport	-0,37	0,15	-18,79	-1,99
Auxiliary modes of transport	-0,51	0,26		-1,31
Post and telecommunications	-1,78	-1,06		-1,84
Financial intermediation and insurance	-0,24	0,55	-20,48	-1,30
Real estate activities	-1,84	-1,05	-18,37	-2,15
Rent of machinery and equipment	0,24	0,84	-18,61	-2,06
Computer and related activities	-1,15	-0,41	-18,63	-1,44
Research and development	-1,95	-0,75	-20,90	
Other business services	-0,04	0,47	-22,51	-0,72
Public administration and defense	-4,88	-4,10		-1,24
Education	-4,50	-3,57	-22,12	-0,61
Health and social work	-4,48	-3,64	-20,86	-1,14
Sanitation and waste management	-3,60	-1,70		-1,76
Activities of membership organizations	-4,85			-0,92
Recreational cultural and sporting events	-2,69	-1,89	-17,68	-1,35
Other activities, domestic work	-0,56			-0,42

Source: author's estimates

Table 13. Changes in prices of output, industry revenues, costs of intermediates in production of manufactured goods and services, in the Central scenario, static model

Short name of activity / commodity group	Change in output price, %	Change in industry revenue, %	Change in the price index of intermediate products, %
Agriculture	-0,44	-0,42	0,07
Logging	0,21	0,09	1,39
Fishery	1,82	1,16	3,32
Coal and peat	0,25	0,22	-0,18
Crude oil	-1,69	-1,26	-0,47
Natural gas	0,14	0,22	-0,57
Services related to oil and gas prod.	-0,61	-0,61	-0,40
Other minerals	1,02	0,81	0,46
Food products	-0,19	-0,20	0,05
Beverages	-0,40	-0,41	-0,09
Tobacco products	0,63	0,61	2,05
Textile products	0,56	0,49	1,36
Clothes and fur	0,33	0,26	1,58
Leather products	0,10	0,05	0,81
Wood	-0,84	-0,82	-0,73
Paper	0,16	0,03	0,68
Publishing and printing	-0,57	-0,56	-0,20
Coke and petrochemical products	2,84	2,01	3,36
Chemical products	0,51	0,47	1,32
Rubber and plastic products	-0,05	-0,09	0,22
Other non-metallic mineral products	-0,50	-0,50	-0,22
Metals	-0,91	-0,88	-0,91
Finished metal products	-1,50	-1,40	-1,61
Machinery and equipment	-0,68	-0,70	-0,43
Office equipment and computers	1,00	0,74	1,99
Electrical machinery	-1,01	-0,97	-0,94
Radio, television and communication equipment	0,58	0,46	1,55
Precision and optical instruments	-0,45	-0,47	0,15
Motor vehicles	0,91	0,83	1,49
Other transport equipment	-1,06	-1,02	-0,98
Furniture, recycling	-1,15	-1,12	-1,22
Power supply, steam and hot water	-1,23	-1,21	-1,43
Collection and distribution of water	-1,18	-0,89	-0,65
Construction	-0,54	-0,54	-0,07
Trade	-0,79	-0,71	-0,36
Hotels and restaurants	-0,45	-0,46	
Transport	-0,23	-0,25	0,39
Auxiliary modes of transport	-0,44	-0,45	
Post and telecommunications	-0,46	-0,46	
Financial intermediation and insurance	-0,85	-0,85	-0,50
Real estate activities	-0,74	-0,74	-0,62
Rent of machinery and equipment	-0,73	-0,73	-0,06
Computer and related activities	-0,42	-0,43	0,44
Research and development	-0,62	-0,64	-0,08
Other business services	-0,75	-0,75	-0,20
Public administration and defense	-0,74	-0,74	
Education	-1,06	-1,06	-0,47
Health and social work	-0,64	-0,64	0,51
Sanitation and waste management	-0,26	-0,37	
Activities of membership organizations	-0,86		
Recreational cultural and sporting events	-0,74	-0,74	-0,21
Other activities, domestic work	-1,11		

Source: author's estimates

Table 14. Social accounting matrix for 2011, trln (10**12) Rub, nominal prices

	1	2	3	4	5	6	7	8	9	10	11	12	13	14	15	16	17	18	19	20	21	22	23	24	25	26
	cagr	cext	cmnf	ctrn	ctrd	csvr	aagr	aext	amnf	atrn	atrdr	asrv	trsc	lab	cap	T_Y	S_Y	T_F	T_FY	T_D	gov	hh	ent	s-i	row	tot
1	cagr						0,725	0,001	1,518	0,004	0,011	0,119									0,036	1,315		0,176	0,214	4,117
2	cext						0,004	0,352	2,728	0,033	0,071	0,534									0	0,009		0,589	3,512	7,832
3	cmnf						0,644	0,517	8,164	0,956	0,55	4,458									0,099	7,673		5,252	5,654	33,966
4	ctrn						0,072	0,473	0,968	0,943	1,802	0,557	0,672								0,102	0,948			0,647	7,184
5	ctrd						0,042	0,096	0,099	0,041	0,331	0,074	12,791												0,001	13,646
6	csvr						0,245	0,859	2,679	1,534	2,215	9,404									10,452	9,519		7,728	0,774	45,409
7	aagr	3,58	0	0,342	0,011	0,013	0,027																			3,974
8	aext	0,001	6,753	0,407	0,027	0,027	0,146																			7,361
9	amnf	0,034	0,766	23,377	0,065	0,517	0,338																			25,097
10	atrnr	0,002	0,005	0,03	6,543	0,056	0,155																			6,791
11	atrdr	0,003	0,03	0,41	0,206	12,849	0,703																			14,2
12	asrv	0,004	0,017	0,386	0,07	0,182	42,877																			43,537
13	trsc							0,178	0,099	1,798	0,188	0,118	1,76								0,06	6,427		0,809	2,026	13,463
14	lab							0,373	0,574	2,188	1,163	2,259	9,741													16,297
15	cap							1,64	4,158	4,06	1,454	6,182	13,782													31,277
16	T_Y							0,023	0,015	0,166	0,062	0,023	0,626								0,004	3,245		0,182	3,852	8,198
17	S_Y							-0,056																		-0,056
18	T_F							0,084	0,151	0,641	0,355	0,58	2,151													3,962
19	T_FY								0,068	0,089	0,058	0,058	0,332													0,605
20	T_D																					2,168	2,451			4,619
21	gov															8,198	-0,056	3,962	0,605	4,619						17,328
22	hh													16,297									22,219			38,516
23	ent														31,277											31,277
24	s-i																				1,088	7,041	6,607			14,736
25	row	0,493	0,26	9,014	0,261	0,003	1,163														5,487					16,68
26	tot	4,117	7,832	33,966	7,184	13,646	45,409	3,974	7,361	25,097	6,791	14,2	43,537	13,463	16,297	31,277	8,198	-0,056	3,962	0,605	4,619	17,328	38,516	31,277	14,736	16,68

Source: author's estimates

Table 15. Key for SAM rows

#	Code	Description	#	Code	Description
1	cagr	goods of agriculture industries	14	lab	factors of production: labour
2	cext	goods of extraction industries	15	cap	factors of production: capital
3	cmnf	goods of manufacturing industries	16	T_Y	taxes: excises
4	ctrn	goods of transportation industries	17	S_Y	subsidies on production
5	ctrd	goods of trade industries	18	T_F	taxes on factors of production
6	csvr	activities of services industries	19	T_FY	taxes on production
7	aagr	activities of agriculture industries	20	T_D	direct taxes
8	aext	activities of extraction industries	21	gov	government
9	amnf	activities of manufacturing industries	22	hh	households
10	atrn	activities of transportation industries	23	ent	enterprises
11	atrdr	activities of trade industries	24	s-i	savings-investment account
12	asrv	activities of services industries	25	row	rest of the world account (row of imports and column of exports)
13	trsc	transaction markups	26	tot	totals

Source: author